

NETL TRANSFER



HN 5SIP U

# HORSE PACKING

By

CHARLES JOHNSTON POST



G 2775.27

HARVARD COLLEGE  
LIBRARY



FROM THE BEQUEST OF  
ROLAND BURRAGE DIXON  
CLASS OF 1897  
PROFESSOR OF ANTHROPOLOGY  
1916-1935





# HORSE PACKING



# HORSE PACKING

BY

CHARLES JOHNSON POST

Formerly First Lieutenant and Battalion Quartermaster

71st Regiment, N. G. N. Y. and First Lieutenant

8th Coast Artillery, N. G. N. Y.

Author of "Across the Andes"

A Manual of Pack Transportation



*Number 49*



NEW YORK  
OUTING PUBLISHING COMPANY  
MCMXIV

△  
SG 2775.27

✓  
HARVARD COLLEGE LIBRARY  
BEQUEST OF  
ROLAND BURRAGE DIXON  
MAY 19, 1936

**COPYRIGHT, 1914 By**  
**OUTING PUBLISHING COMPANY**

**Entered at Stationer's Hall, London, England.**  
**All rights reserved**



## INTRODUCTION

Ordinarily a book of this kind needs no introduction; it either explains itself in the clearness of the diagrams and pages or else it is so didactically incomprehensible that no amount of introduction could possibly clarify the atmosphere.

But I am under obligations to various gentlemen whose suggestions, or methods, have appeared to me of great value in presenting and arranging this subject. There is the unknown gentleman—perhaps many of them—who have devised or evolved the typical method of preparing Army drill regulations of the United States. It is the most compact, exact and limpid method of standardizing and transmitting information of this character that has been devised. A thousand years from now men who have never seen the execution of an evolution of our present generation could work and drill in the forgotten manoeuvres with as great an exactness as soldiers are drilled to-day. And that is the test of clearness.

I have therefore adopted the method of the Army manual—not that I intend it as a rigid method of execution for packs or hitches, but that it is absolute in its

exact directness of explanation. Whether a packer sings out, "Kill 'em." or "Cinch!" is a matter of no importance—I have no intention of offering a mere vocabulary—but that, at certain stages of throwing a hitch, some signal facilitates the work, is a matter of importance. So I have given an apparent formality to methods solely for purposes of clearness. When two men understand each other—as I have seen a team of packers work in loading an Army mule—there appears a conjurer's rope that seems to fairly flow in even coils through the mazes of an intricate hitch, suddenly to grow rigid as the mule grunts while the watch has ticked off but fifty seconds.

I am also under obligations to War Department Document No. 360, a most interesting compilation of pack transportation in the Army, and to the able contributions that Mr. H. W. Daly, Chief Packer of the Quartermaster's Department has made to that Document, and to Col. Hugh L. Scott who assisted in its preparation. Colonel Scott describes Mr. Daly as one of the last of the old-time packers who grew up with the pack service under General George Crook. He ascribes to him the study that resulted in the discovery of the cause of the bunches that arise on the pack animal's body; to him also the method of curing the bunches and various inventions that have added greatly to the service and development of scientific pack transportation in the United States Army. I have given the detailed specifications for the aparejo from this document so that, if necessary, the aparejo may be made when needed.

I wish also to make my acknowledgment of appreciation to Sergeant Wiman of the Quartermaster's Department in charge of the pack transportation at West

Point. I first heard of the Wiman One-man Hitch, described in this present manual, from him. It is beyond question the best of all the one-man hitches.

Therefore, if this manual seems to have an Army flavor, it is by reason of collecting in a simple intelligible form all of the important hitches used in pack transportation and with such suggestions that they may be employed as circumstances demand. It is the purpose that this shall be offered for the needs of the explorer, the prospector, packer, the Army service or the pack service in the National Guard.

And I have relied upon diagrams to express the simple stages of a hitch.



## Table of Contents

	Page
Introduction .....	7
Definitions .....	11
General Rules .....	14
Organization for Military Purposes.....	15
Marches .....	16
Records of Endurance .....	17
<b>Standard</b> Pack Mules .....	19
Diseases of Pack Animals .....	23
The Aparejo .....	24
Care of the Pack Animal .....	32
Specifications for Aparejo .....	34
Latigo .....	50
To Lair Up a Pack .....	52
Slinging the Cargo .....	60
One-Man Cargo Sling .....	66
Cross Sling .....	75

### HITCHES

Diamond Hitch, Single .....	78
Diamond Hitch, Double .....	92
Wiman One-Man Hitch .....	104
Pole Hitch .....	114
Saw Buck Saddle .....	122
Saw Buck Slings .....	125
Cross Tree Hitch .....	132
Squaw Hitch .....	140
Lifting Hitch .....	146
Stirrup Hitch .....	155
Saddle Hitch .....	163
To Construct a Travois .....	168
Mule Litter .....	172

### APPENDIX

Cordage, Ropes, Splices Knots, etc .....	173-197
Index .....	199



# HORSE PACKING

## DEFINITIONS

- Aparejo*—The type of pack saddle that is solely a pad for the animal's back.
- Bell Horse*—A horse (or mule) with a bell fastened to its neck. It marches at the head of a pack train.
- Bivouac*—To camp without tents. A hasty camp in the open.
- Blind*—A hood to cover the eyes of the animal when loading it.
- Brake*—To balance or even the two side packs on the animal.
- Breast Strap*—A band or strap that is attached to the saddle and that passes across the animal's breast to keep the load from slipping back.
- Bunch*—A swelling or puffing up, like a bruise, caused by the over pressure in that spot of the saddle or load.
- Cargo*—The collection of freight for a pack train or pack animal.
- Cargador*—The assistant to a pack master.
- Chief Pack*—The head of any number of pack trains. The head of any system of Pack Transportation.
- Cincha (or Cinch)*—The broad band that comes beneath the animal's belly and on which the strain of the hitch comes. A cincha with its attached latigo are commonly known as the cinch.
- Cinch—To Cinch*—To tighten to the limit, as a lash rope, a latigo, a girth, etc.
- Corona*—The saddle pad or blanket that is first placed on the animal and that comes next to its hide.
- Cross-Tree*—Another name for the saw buck pack saddle.
- Crupper*—The band that passes from the saddle under the animal's tail or dock. It keeps the saddle from slipping forward.
- Dock*—The root of the tail.

- Dock-piece*—That portion of the crupper that fits under the dock.
- Girth*—The band or strap encircling the animal or passing under it by which the saddle or aparejo is held in place on the animal's back.
- Hitch (in pack transportation)*—The term by which any method of attaching a load to the back of an animal by means of a rope is known. Securing a load by a hitch is known as "Throwing the Diamond (or such-and-such) Hitch."
- Lair Rope*—The rope by which a pack is lashed in a load either by itself or in a manta or pack cover. It is about 30 feet long.
- Load*—The whole burden for one animal.
- Lash Rope*—The rope, about 40 to 50 feet in length, by which the hitch is thrown and the load lashed on the animal.
- Latigo*—The strap attached to a cincha or saddle for the purpose of securing the cincha or girth around the animal through a ring (rendering ring) at the other end.
- Near Side*—The left side of an animal.
- Off Side*—The right side of an animal.
- On Side*—The near side of an animal. Same as near side.
- Pack*—One side of the load on an animal, as the near pack, the off pack.  
(*To Pack*—To load the animal or animals. Also the act of transporting by the backs of animals.)
- Pack Cover*—A square of canvas (about 6 by 6 feet) in which the component parts of a pack are lashed.
- Pack Blanket*—A blanket placed under the pack saddle or aparejo.
- Packer*—One qualified to pack the cargoes and throw the hitches.
- Pack Master*—One who is in charge of a pack train.
- Pack Saddle*—Any arrangement or device for carrying freight on the back of an animal, in distinction to the Aparejo which may be a pad of the simplest description.
- Pack Train*—Any number of pack animals operating in a single unit. The standard military pack train consists of 50 pack mules, complete equipment, 14 men, 14 riding mules and 1 bell horse.



**Picket Rope**—A rope used to tether an animal and keep it from wandering while grazing. Also the rope to which many animals are fastened in rank.

**Rendering Ring**—The ring through which the Latigo is passed to cinch it and make it fast.

**Riding Load**—The load or pack that is carried above and between the two side packs.

**Rigging**—The complete aparejo.

**Running Part**—Same as *Running Rope*.

**Running Rope**—That part of a rope between the free end and that place on the Rope at which movement, as in pulling or tightening, ceases. Thus, in a block and pulley the portion of the rope between one pulley and where it is fastened to the bottom of the other pulley, never moves, as do the other ropes in hauling; it is the standing part. The rest is the Running Part or Parts. It is the same in the turns of any hitch, one portion of the rope is immovable on the packs; the rest is the *Running Part*.

**Saw Buck Saddle**—See Chapter for description of the same.

**Sling Rope**—The rope used to hold the packs on the animal's back in the proper place so that the hitch may be thrown. It is about 30 feet long.

**Sobre-jalma**—The aparejo cover with the heavy horizontal sticks on each side that holds the lower turns of the hitch on both sides. (Variously known as the sobber hammer, soldier hammer, sovereign, etc.)

**Standing Part**—See *Running Rope*.

**Standing Rope**—See *Running Rope*.

**Striding Load**—Same as *Riding Load*.

**Top Load**—Same as *Riding Load*.

## GENERAL RULES

Pack animals should be allowed to drink on the march, when they indicate their thirst at fords, etc.

Pack animals should be groomed, etc., and treated on the same basis as a saddle animal, in order to get the best results.

Their backs should be carefully examined for burrs before putting on the blanket or aparejo. The hair should lie smooth and in one direction.

A pack animal must always be blinded when putting on the aparejo and loads. If necessary to move to another position, remove the blinders, move, and then put them on again.

A pack animal, when he puffs himself up while being loaded or just before cinching, *should not be kicked in the belly to expel the wind*. Puffing gives the animal a brief pleasure and does not affect the lashing or cinch any—for it has to be tightened anyway a second time shortly after the march begins, owing to the stretch and give of the rope.

The animals should be treated with kindness.

A pack animal must have confidence at all times in the men of the outfit for without such implicit confidence, time is lost in packing and a thousand other irritating ways. The man is not on the animal's back all the time with spur and bit to hold him in hand and therefore confidence, and affection, if possible, should be established by uniform kindness. Fords, bad trails, etc., can be negotiated when this confidence exists where there would otherwise be nothing but balkiness and confusion.

A load should never be adjusted uphill. Turn the animal so he faces downhill.

Keep the pack train closed up, head to haunch. Do not allow it to straggle out. A wild and erratic animal may be haltered to the pack ahead. Generally a pack train quickly settles down to the single file.

The complete march for the day should be made without an extended "rest halt" if possible, and then go into the day's camp. In a hilly or mountainous country, short halts are necessary to straighten the loads, tighten them, etc.

If a pack animal falls and it is necessary to cut the lash rope, cut it at the standing part. It will more quickly drop the load and do less injury to the rope.

The aparejos should be removed at the end of a march and the animals allowed to roll. This is true unless their backs are lathered and overheated and the air is too keen or cold.

When emergency compels the packing of very heavy loads beyond the normal, or there is a long march, do not allow the animals to wander from the single file or lie down. Every means should be used to keep them on their feet and marching. They can keep on marching when, if they lie down, they cannot get on their feet again even with the load off. Stupendous loads have, in emergencies, been packed on mules who could carry it as long as they were marching. This is a rule for *emergency* only, "keep them going."

When two or more packers are with an outfit the one man hitches should never be used. Two packers should always work together.

Pack transportation is continually a matter of judgment, experience, and common sense. It cannot be formalized like a military manoeuvre. It is intended for the most flexible and mobile service under all conditions, whether in the field of exploration or for military purposes.

Efficiency can best be secured by preventing inexperienced interference.

### **STANDARD OF ORGANIZATION FOR MILITARY PURPOSES**

A Pack Train consists of:

*50 Pack Mules,  
1 Bell Horse,  
and 14 Riding Mules.  
1 Pack Master,  
1 Cargador,  
1 Blacksmith,  
1 Cook,  
and 14 Packers,*

with complete outfit for camp and subsistence and the requisite number of riding saddles and aparejos.

### MARCHES

On a road or trail in ordinary country a pack mule with a load of 250 pounds can make 25 miles a day without difficulty. This is the ordinary military load and march. And a pack mule can keep this up practically twelve months of the year if his back be kept free from sores.

NOTE.—This assumes the United States Army aparejo. This aparejo enables a packer to cure the preliminary "bunches" or saddle bruises before they can develop into sores. Of no other known pack saddle or device is this true. The saw buck is good for light and occasional use or where mules can be worked in relays, but to keep one train of pack animals *constantly in the field* under ordinary or heavy pack work the Army aparejo is the only packing outfit that can be used and keep the animal's back fit.

Over a rough, hilly and mountainous country a pack mule will carry 250 pounds and march 10 to 15 miles, depending on the difficulties.

The following table is the standard rate of march under varying loads for the United States Army:

Weight of Load.	Maximum rate of travel per hour.	Number of miles per day.	Number of days of continuous travel.
200 pounds .....	8	25	7
" .....	7	40	10
" .....	6	50	7
" .....	6	100	3
" .....	5	25	365
250 pounds .....	8	25	3
" .....	7	40	7
" .....	6	100	1
" .....	6	50	5
" .....	6	25	30
" .....	6	20	60
" .....	5	100	2
" .....	5	50	10
" .....	5	25	60
" .....	5	20	90

Weight of Load.	Maximum rate of travel per hour.	Number of miles per day.	Number of days continuous travel.
300 pounds .....	5	75	1
“ .....	5	50	7
“ .....	5	25	30
“ .....	5	20	60
350 pounds .....	4	20	30
400 pounds .....	4	15	30

### RECORDS OF ENDURANCE

The endurance of the pack mule is amazing. The following are from the official records of the United States Army:

In 1881 a company of Indian scouts and one pack train made a march of 85 miles in 12 hours under loads of 200 pounds to each animal. This was under Colonel Buell of the 15th Infantry against the Apaches.

A company of Indian scouts and one pack train later, but in pursuit of the same Apaches, marched about 60 miles between sunrise and sunset. They were then loaded on cars and shipped by rail to Fort Craig, New Mexico, and marched across some 30 miles to the San Mateo mountains, loaded 250 pounds to the mule; then without making an all-night camp struck the trail of the Apaches and followed it into Old Mexico. About 300 miles was covered in about four days.

From San Carlos Agency, Arizona, in 1882, a company of scouts and one pack train, loaded 200 pounds to the mule, made a forced march of 280 miles in three days.

In 1891 and 1892, during the Garza campaign on the Rio Grande, Texas, a troop of the 3rd Cavalry and part of a pack train, loaded 250 pounds to the mule, were marched 108 miles in 16 hours.

In the same campaign another pack train marched 104 miles in a night and part of the following day.

Also in the same campaign another pack train made 90 miles in less than twenty-four hours, each mule loaded with 250 pounds.

These mules were in perfect condition—not from long rest—but from constant and properly supervised use. Of course, after such heavy strains they were given a day's rest to regain their normal condition.

The writer has made a forced march across a South American desert with a pack train of the little native mules. In 26 hours they marched a shade over 100 miles, with one halt of 10 minutes and one of 2 hours at a camp by water. At the finish one mule broke into a trot as it recognized the station some three miles away and trotted up to the rails showing but little signs of fatigue. A careful comparison with the invoices showed that it had been carrying a weight of a little over 400 pounds. Native packers were used and they thought this nothing unusual.

Another instance was that of a little South American mule that carried a revolutionary field gun weighing 600 pounds a distance of 6 miles and with the half-breed packer *riding on top in addition*. The minute the mule halted, it dropped under its burden as if shot. The native packer was punished.

In the Philippine Islands the mount of a navy rapid-fire gun of the U. S. gunboat "Quiros" was carried three miles inland on a pack mule, and later back to the gunboat again. It weighed 540 pounds and was carried by the mule over the poor trails or cross country on the Island of Jolo.

**DESCRIPTION OF STANDARD PACK MULE**

To be of sound body, chunky and solid in build, and at a walk or trot with a firm, free and springy action.

To be between 4 and 6 years old, and weight between 950 and 1,020 pounds, and run from 14.1 to 15 hands high. Larger size, if possible is no bar, if the general type of efficiency and action is the same.

Head of medium size, intelligent and well-formed, not Roman nosed or too large. Between the eyes, broad.

Eyes clear and large and NOT inclined to show the white.

Teeth sound, tongue good and clear, mouth and muzzle well formed and firm; avoid a hanging under lip.

Neck, inclined to arch, stocky and full. The withers should be low and broad.

Chest, holding therefore legs well apart and indicating good capacity of lungs. The division well marked. Not high at center.

Knees, wide in front and without blemish

Back, straight and short showing a strong back over kidneys.

The barrel should be deep and large, with hips well rounded and broad.

The dock should offer springy resistance.

Hocks, well apart, and strong; pasterns, short and strong, without scratches, cuts or bruises.

Hoofs, broad, sound and full with the frog well developed, elastic and healthy.

# HORSE PACKING

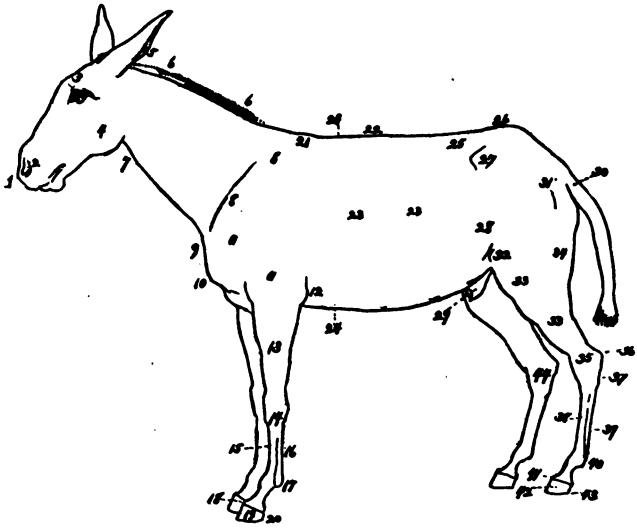



**POINTS OF A PACK ANIMAL****Head**

- |              |          |
|--------------|----------|
| 1. Muzzle.   | 4. Jaw.  |
| 2. Nostril.  | 5. Poll. |
| 3. Forehead. |          |

**Neck**

- |                 |                          |
|-----------------|--------------------------|
| 6, 6, 6. Crest. | 7. Throttle or windpipe. |
|-----------------|--------------------------|

**Fore Quarter**

- |                       |                               |
|-----------------------|-------------------------------|
| 8, 8. Shoulder Blade. | 15. Cannon bone.              |
| 9. Point of shoulder. | 16. Back sinew.               |
| 10. Bosom or breast.  | 17. Fetlock or pastern joint. |
| 11, 11. True arm.     | 18. Coronet.                  |
| 12. Elbow.            | 19. Hoof or foot.             |
| 13. Fore-arm (arm).   | 20. Heel.                     |
| 14. Knee.             |                               |

**Body or Middle Piece**

- |   |                                   |
|---|-----------------------------------|
| 21. Withers.  | 25. The loins.                    |
| 22. Back.   | 26. The croup.                    |
| 23, 23. Ribs (forming together the barrel or chest).      | 27. The hip.                      |
|   | 28. The flank.                    |
|   | 29. Sheath.                       |
| 24, 24. The circumference at this point called the girth. | 30. The root of the tail or dock. |

**Hind Quarter**

- |                                |                               |
|--------------------------------|-------------------------------|
| 31. The hip joint.             | 38. The cannon bone.          |
| 32. The stifle joint.          | 39. The back sinew.           |
| 33, 33. Lower thigh or gaskin. | 40. Pastern or fetlock joint. |
|                                | 41. Coronet.                  |
| 34. The quarters.              | 42. Hoof or foot.             |
| 35. The hock.                  | 43. Heel.                     |
| 36. The point of the hock.     | 44. Spavin place.             |
| 37. The curb place.            |                               |

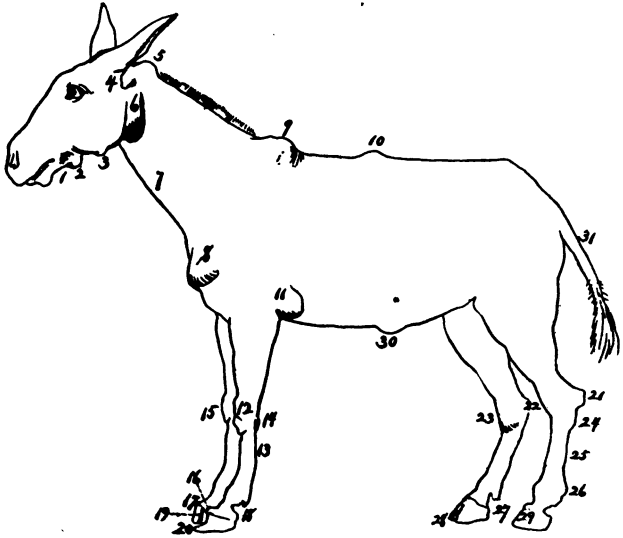

*DISEASES OF THE PACK ANIMAL*

1. Caries of the lower jaw.
2. Fistula of the parotid duct.
3. Bony excrescence or exostosis of the lower jaw.
4. Swelling by pressure of bridle.
5. Poll evil.
6. Inflamed parotid gland.
7. Inflamed jugular vein.
8. Fungus tumor, produced by pressure of the collar.
9. Fistula in the withers.
10. Saddle Gall.
11. Tumor of the elbow.
12. Induration of the knee.
13. Clap of the back sinews.
14. Malanders.
15. Splint.
16. Ringbone.
17. A tread upon the coronet.
18. Quittor.
19. Sand crack.
20. Contracted or ring foot of a foundered animal.
21. Capped hock.
22. Malanders.
23. Spavin.
24. Curb.
25. Swelled sinews.
26. Thick leg.
27. Grease.
28. A crack in front of hoof, called cow crack.
29. Quarter crack.
30. Ventral hernia.
31. Rat tail.

### THE APAREJO.

In reality the load lashed on the aparejo is carried virtually on the ribs; their resilience taking up the galling pounding of a dead load, or adjusting it to a most remarkable extent. In addition to this the manner of padding the aparejo is such that galls, bruises, bunches, etc., can be cared for, or rather the pressure of the padding on those parts can be eased away so that Nature itself can relieve and cure the point of hurt.

*Ribs for the Aparejo.*—A reference to the accompanying diagram and illustration will clearly show what is meant by "ribbing" the aparejo, and also demonstrate the essential principle of the aparejo as against other forms of pack saddle.

The important principle in ribbing the aparejo with these small sticks is that the diameter of the first one shall be greatest at the front of the aparejo and then the others shall lessen gradually in diameter till the slenderest rib is at the rear.

An aparejo will require from fifty to sixty sticks, or from twenty-five to thirty on each side.

The first stick on each side that is placed under the collar or forward end should be of about  $\frac{3}{4}$  of an inch in diameter. The diameter of the last stick must be  $\frac{3}{8}$  of an inch. The sticks should be selected and laid out beforehand in a row in the order of their diminishing diameters. Any not clear, straight and sound must be rejected. This is for the ordinary load of 250 pounds. For heavier loads slightly, very slightly heavier ribs must be made.

The butt end of each rib should be cut square across, i. e., flat, and have been cut to a slight taper for about two inches. This is for greater ease in holding to the flat surface of the boot stick.

*Kind of wood for ribs.*—The ribs must have toughness, springiness or resilience, straightness, freedom

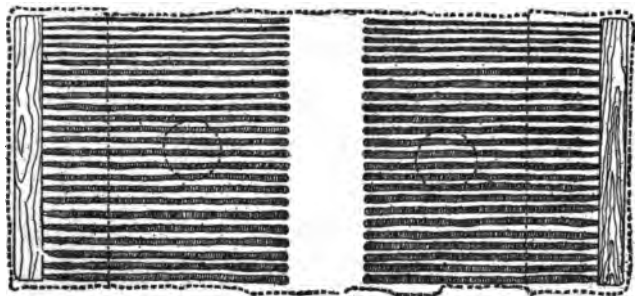

X-Ray of Aparejo showing arrangement of strips.  
The Aparejo is laid out flat.

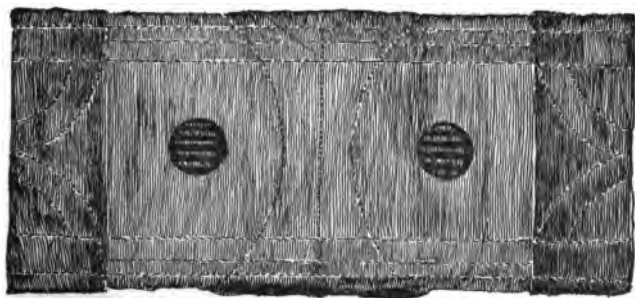

The Aparejo showing hand-holes.



Wedge shape stick for tamping grass in boot of aparejo.

from any irregularities or knots or blemishes, and a slow, even taper.

Natural sprouts are generally most available where pack transportation is needed and are ordinarily quite as good if not superior to any fancy woods from the shop. Also they are most easily renewed when necessary and without delay. (For standard hickory ribs made in shop see Hickory Ribs.)

The willow is excellent and found in some variety almost everywhere. The gray, black, red, button, and desert willows are the most suitable. Dogwood and arrowwood are generally too short and irregular but are good if the other conditions are met. The guayaba (generally known in the United States as "guava") of tropical countries has been found to furnish excellent sticks for ribbing aparejos. But ash, hickory or pecan sprouts have been found to give the very best results when it is possible to secure them.

*Boot-sticks.*—These boot-sticks are of a hard wood,  $21\frac{1}{2}$  inches long,  $2\frac{1}{2}$  inches wide, and  $\frac{3}{4}$  of an inch thick. The ends must be rounded on one side.

*Ribbing the Aparejo.*—The aparejo should be first soaked in water for about a half an hour; if the water is slightly warmed one-half that time will be sufficient and then drained.

The boot-sticks are then inserted so that the rounded ends face the inside of the back piece of the aparejo. Under no circumstances must a boot-stick be forced into place for then as the leather dries the strain will burst the stitching or rapidly wear a way through. The boot-stick is introduced through the hand hole and adjusted across the bottom of the boot, the flat surface of the boot-stick to face the inside belly piece.

Now introduce through the hand hole the largest rib, butt end first, placing it in the forward corner of the boot, the end of the stick resting against and over the flattened surface of the boot-stick. The rib must be of the right length and never too long or too short.

It is best that the ribs be selected, or graded as to diameter, in pairs so that the corresponding ribs on each side of the aparejo are put in place practically together.

Each rib should be measured for the position it is

to occupy before inserting. Place butt end on the aparejo resting on the lower edge of the boot-stick in line with the stitching of collar at its forward end. Cut the stick at the place indicated by the forward part of the stitching and round off the end.

The aparejo should be ribbed as described with a gradually diminishing diameter of ribs until the forward half of the ribs are in place. Then begin at the rear in the same manner as described and rib forward, beginning at the rear with the rib of smallest diameter and steadily increasing toward the center.

The aparejo is now ribbed.

*Padding the Aparejo.*—Hay, of the proper quality, is the most easily obtained padding under almost all circumstances. The best hay is the thin, wiry grass such as is often used for the ordinary packing of merchandise. It must be of even quality and of such a character that it does not mat, but can be easily separated and diminished in any spot desired yet without disturbing or distorting the whole mass of adjoining padding. Moss or similar substances may be used in emergencies.

A stick for tamping is now needed and the end is shown in the illustration; the grooved end shown is for the purpose of holding a grip on the hay.

Stand the aparejo up on its boots with the hand holes facing out. In small quantities the hay is introduced into the aparejo and pressed into the corners of the boots. Tamp well with the stick. The four corners should each be equal.

Along the center of the boot the hay is tamped lightly. The boot when tamped should have a thickness of about 4 inches and a depth of about the same.

Now spread the aparejo out upon the ground with the hand holes uppermost. Examine it to see that the ribs are all in place and adjust any that have been worked out of position.

Through the hand holes introduce one layer of hay spreading it evenly over the ribs. The tamping stick may be used to reach the more remote sections. Be sure that the hay lies evenly and of an equal thickness, without lumps or variations in thickness. Then lay in a second course of hay. Experience alone can de-

termine the amount—and the ease with which more may be added or some taken away makes this a matter of less importance than were the paddings to be sewn in—but after the hay has been well settled in place by a little actual use the thickness throughout the body of the aparejo should be about 2 inches.

The aparejo should have a rather thin appearance and not appear fat with padding.

The thickness of the padding at the boots is 4 inches, from this it decreases to the hand holes to about 2 inches. At the top or center the normal thickness extends to within about 4 inches of the center stitch line and then gradually decreasing to the middle seam where it is practically nothing.

This is the basic padding. Additional padding for the aparejo is now added in order to conform to the shape of the animal.

Each front boot is now dressed or faced, as it is called. Extra padding is inserted in the front corner to a distance of about 7 inches from the corner. The original bed of padding must not be disturbed in this process; it can be avoided by introducing the additional padding with the palm of the hand up. For the next 4 inches the padding rapidly decreases in thickness toward the hand hole.

The front boot should be better padded than the rear; for ordinary mules the difference is about 1 inch in thickness. This is a matter of judgment and experience and will vary with the conformation of the mule; the larger the girth the more padding is need to make the aparejo sit well on the animal.

Under the collar of the aparejo should now be placed padding to fit the withers of the animal. Insert the hay with the back of the hand down so as not to disturb the previous layer and carry the hay well into the corners of the front. Increase the width and depth of the padding as you get away from the corners. Then decrease the thickness of the padding as the center and hand hole is approached. The thickness of padding is governed by the height to the animal's withers.

These paddings should be of such thickness and adjustment that when the aparejo is cinched the top



should be level and the bottom of each boot level and even with each other.

The front edge, between the boot and collar may now have an additional line of padding added between the boot and collar so that the aparejo may better conform to the body of the animal in cinching.

The aparejo is now set up.

*Lacing the Crupper.*—Fasten the leather thong through the upper hole on the crupper. (There are 2 thongs each about seven feet long, one for each side.) Lace the crupper to the forward facings as shown in the illustration so that the tie shall come at the last hole of the crupper. The lacing must begin at the top and work down.



*To fasten Sobre-jalma or Aparejo Cover.*—Punch two holes at each end of the aparejo and in the center (they will come just over the back bone of the animal) and fasten a short thong in each. Punch two holes in corresponding positions in the aparejo cover or sobre-jalma. Lash the sobre-jalma in place with the thongs.

The aparejo is now ready for use.

*Adjusting the Aparejo.*—This can only be done ap-

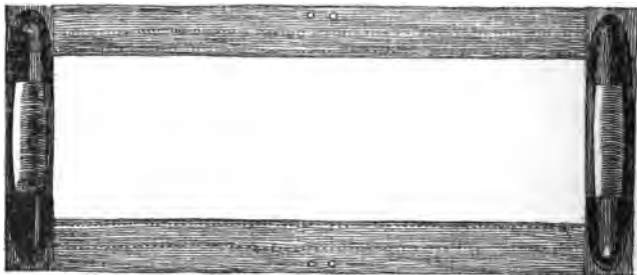

### The Sobre-jalma

proximately at the time of the first saddling. An animal should be fitted with its aparejo and worked in it, such changes being made in its padding as are apparently demanded so that it will the better conform to the shape of the animal, and such as are needed from time to time by the development of bunches. (See Care of the Pack Animal, Bunches and Swellings.)

*Sore Docks or Tails.*—Should the crupper cut the animal's tail or dock it is an indication that the aparejo does not fit properly; that there is too much filling in the boots to the rear. If the boots at the rear are too thickly filled, or the aparejo generally too heavily padded at the rear, it cannot grip the animal's body properly so as to prevent a too great forward motion in travel that the crupper against the dock and chafes it into a sore.

An aparejo should never be less than 24 inches wide in order that there may be a sufficient bearing surface on the body of the animal to hold it properly in place. With too small a bearing surface the aparejo works

out of its position and either makes a constant and wearing adjustment necessary throughout the march or wears sore tails.

*Care of the Aparejo.*—The leather equipment should be cleaned whenever they become dirty with dirt and grit or dust and whenever they become saturated with the sweat of the animal. Do not separate the crupper from the aparejo. Wash with a lather of castile soap and water. If the leather is hard and dry apply a little neat's-foot oil after the washing with castile soap. The surplus oil should be sponged off with soap and water lightly applied.

There are in general use the 62, 60, and 58 inch aparejos, i. e., measuring from end to end 62, 60, and 58 inches, respectively.

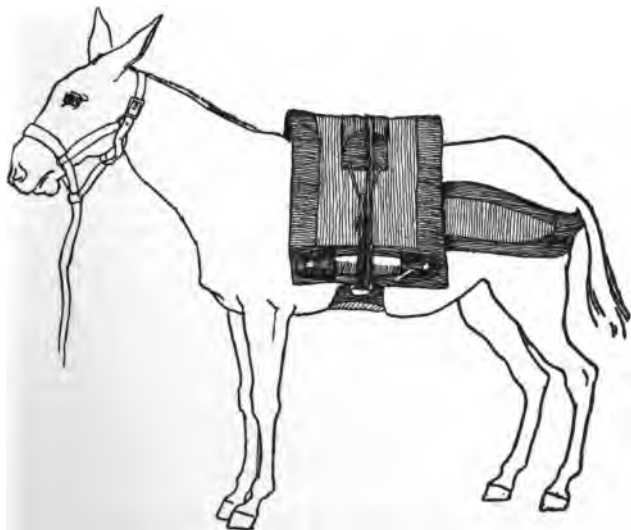

### CARE OF THE PACK ANIMAL.

*Sore Withers.*—If the aparejo is ribbed with too weak ribs it will cause sore withers; this may lead to thissolow or fistula. The size of ribs given in the preceding pages is for the ordinary, standard Army load of 250 pounds.

Sore withers are also caused by not sufficient padding under the collar of the aparejo.

*Sore Loins.*—The causes are the same for this as for sore withers.

*Note.*—It should be emphasized that if too large sticks used in ribbing are too stiff, they will not easily break in with the shape of the animal. They should be used, only slightly heavier, when very heavy loads are to be regularly carried for a trip, that is, loads of 300 pounds and upwards.

But these are matters that can only be acquired by actual experience. The printed page can only outline standards and possible variations.

*Bunches and Swellings.*—A bunch is a swelling, a puffing up, under the skin. It shows an uneven pressure or bearing in the aparejo or the load. It is from these small bunches that the galls and saddle sores develop under continuous use and that have been regarded as a necessary incident of packing.

A bunch almost always is the result of unevenness in ribbing or padding; in other words, it is a bruise. It is exactly parallel to the results caused by a wrinkle in the sock of a man on a march. Slight in the beginning yet it can break down a marching man in an incredibly short while. So it is with these bruises on pack animals.

*To Cure a Bunch or Saddle Swelling.*—When a bunch, however small, is noted after unsaddling, wet the bunch with water. Now place the aparejo on the animal carefully so that it rests on the animal as it has

been during the march. Take it off and observe where the wet spot of the bunch has left its mark on the aparejo.

Carefully, so as not to disturb the rest of the padding, take the hay from under the wet spot so that no pressure for the next march can fall on the bunch. The principle is identical with that of treating corns with a corn plaster or hollow pad on the human foot.

The bunch will rapidly subside. Gradually replace padding after a cure has been effected where it was taken out until the right quantity has been replaced.

Even though the end of the march has been reached the animal having a bunch should be loaded and marched sufficiently to reduce the bunch. Ordinarily this will be a matter of a few hours. If the bunch is not reduced it will most likely form a "steadfast" which is something on the order of a permanent calous. A neglect of thirty-six hours is sufficient to produce a steadfast from a bunch, while after a neglect of but twenty-four hours a bunch is obstinate and difficult to reduce. Bunches should be properly attended to.

*Belly Bunches.*—When the bunch appears on the belly of the animal it is an indication that the boots of the aparejo have been too heavily padded, thereby forcing the aparejo to stand out from the animal and not conform to its shape, and as a result bringing a concentrated pressure on the belly with the cincha. When such a bunch appears on the belly all the hay or padding should be taken out from the boot across the width of the aparejo.

The aparejo should bend with a certain springiness to the shape of the animal; experience alone can regulate this and recognize its quality. The padding should be adjusted to conform to the irregularities in the form of the barrel of the animal. When these conditions are present the aparejo is well fitted. Then it is only the character of the load and the difficulties of the trail begin to make trouble with the bunches and bruises.

The unapproachable superiority of the aparejo lies in the fact that it can (a) be more perfectly fitted to varying animal conformations than any other pack saddle: (b) that it can be more easily changed under

necessity after such fitting to any other animal of a different conformation; (c) that though bruises and bunches can never be prevented owing to the characteristic action of dead loads and the difficulties of trails, yet, with the aparejo, those bruises and bunches can be cured while continuing on the packing service and without injury to the animal.

### DETAILED SPECIFICATIONS.

Take a 60-inch aparejo as a standard—60 inches long and 24 inches wide throughout its entire length.

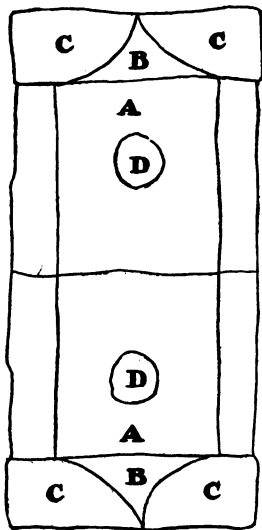

## THE BODY OF THE APAREJO.

(a) The belly or body piece; (b) boots or end pieces; (c) boot facings; (d) hand holes; (e) center facing; (f) front facing; (g) crupper; (h) dock piece; (i) carrier piece; (j) back piece.

Note.—The first two items of the above are sometimes referred to as the "body pieces."

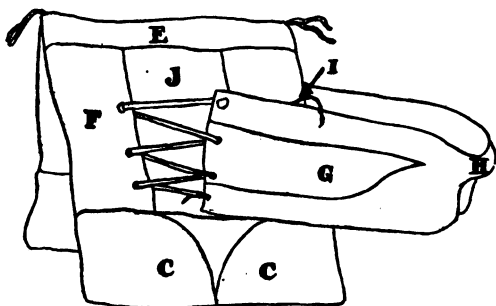

## THE BODY.

To be made of solid, fair leather, tallow finish; sides to be of good spread, weighing from 12 to 14 pounds to the side, free of cuts and blemishes.

Cut the back piece  $43\frac{1}{2}$  inches long and 24 wide. Cut the belly or body piece  $45\frac{1}{2}$  inches long and 24 inches wide.

Cut boots 24 inches long and 18 inches wide. Face the boots at each end with a semicircular facing, facing to be 18 inches long and 12 inches wide, diameter of semicircle to be 16 inches. Facings to meet at center of boot.

The facings must be sewed on with three seams, one-fourth of an inch from their semicircular edges,

and one seam 3 inches from the outward edge all around.

The back piece has a front facing from end to end of  $6\frac{1}{4}$  inches wide. This facing to be of good solid leather, as it is to receive the crupper lacings.

Facing to be sewed down with two seams  $2\frac{1}{4}$  inches from the inner edge for the first, 2 inches from the outward edge for the second.

This facing to have  $5\frac{3}{8}$ -inch holes punched 1 inch from the inner edge and spaced equally distant between the boot and center facing.

Center facing to be 24 inches long and 8 inches wide; to be placed at center of back piece extending from front to rear, sewed down, with two seams on each side at the edge one-half of an inch apart. The front facing on back piece forms the front of the aparejo.

The boots lap on to body pieces  $1\frac{1}{2}$  inches on outside; to be sewed down with three seams, one-fourth of an inch apart and one-eighth of an inch from the edges. In lapping inside to back pieces the fleshy side of the belly piece must face outward.

In closing up the body care should be taken to have the boots or ends doubled exactly alike, so that the top of the boot of belly piece will just meet the end of back or body piece. The center seam to be sewed down to belly and back pieces, and must positively be in the center of the aparejo.

The belly piece will have a "hand hole"  $5\frac{1}{2}$  inches long and 5 inches wide, cut out in center of belly piece 15 inches from center seam to center of hole.

Back piece to have a hand hole of similar dimensions cut in center of back or body piece, 10 inches from center seam to center of hole, this hand hole to be cut around to within 1 inch from either side of center at top. This forms a lid and is provided on the body in line with this, one-fourth of an inch from edge; both holes facing up and down.

On back or body piece at rear a slit 12 inches long is provided; to be 2 inches from the outward or rear edge; commencing with 1 inch above the boot, running upward toward the center seam, and provided with 5 holes on either side of slit, spaced equally distant to receive lacings. These slits are for the purpose of



introducing the inside frame or ribbing for aparejo.

The "hand hole" on back or body piece is provided for guiding ribs to position in boot and saddle bars.

In front there must be a welt of good, solid leather, three-fourths of an inch wide, laid in between the belly and back pieces, extending from end to end, to be sewed down with two seams, three-eighths of an inch apart and one-fourth inch from edge.

In sewing along edge at front, a space of three-fourths of an inch must be omitted, counting  $3\frac{1}{2}$  inches from center seam each way. This to permit "key bar" to pass through in locking ribs of inside frame.

Now punch two holes, three-fourths of an inch apart; the first at center of space, corresponding to hole provided in brass "key bar," the second on the lower side, and provide thong 10 inches long to secure "key bar" to aparejo, both holes to be "up and down."

The rear has a similar welt three-fourths of an inch wide and 14 inches long, extending 7 inches each way from center seam.

Below this the "carrier" pieces are placed for the purpose of carrying the crupper, and are arranged by taking a piece of leather 4 by 8 inches, of half the thickness of the welt, folded the narrow way, slipped in exactly three-fourths of an inch, leaving the folded part out.

The extending part of the "carrier" pieces will have three sets of holes five-sixteenths of an inch in diameter two holes at the upper end and three-fourths of an inch apart, the first hole to be 1 inch from end; two holes will be provided in similar manner at opposite end, and two holes in center in similar manner; the holes to be parallel with the length of "carrier" pieces.

Thongs for each "carrier" piece will provided and to be of latigo leather, 12 inches long and five-sixteenths of an inch wide.

From the "carriers" to the end of the aparejo there must be a welt similar to that described for the front; the whole to be sewed down with two seams in similar manner as described for the front.

The collar that shapes the aparejo for the withers must be 6 inches wide and 6 inches deep; that is to say, 6 inches along the front seam at center and 6

inches back toward rear, shaped in this manner: Three inches on each side of center stitch line of the aparejo, run back 4 inches parallel with center stitch line, then run 2 inches toward center stitch line, then back 2 inches parallel with center stitch line, then up to center stitch line.

The center seam, like center of collar, must positively be in the center of the aparejo and exactly straight across the body.

It is understood the collar is placed on the front as indicated by the front facing of the aparejo, and, like center seam, is sewed to back and belly pieces.

Now punch two holes, one on each side of the center stitch line and to be three-fourths of an inch apart at front and rear, spaced equally distant from center stitch line. These holes to be provided between the two outward seams with thong 10 inches long for lacing, to secure aparejo cover to aparejo.

If using willow or other sticks cut two slits 2 inches long, one on each side of center stitch line, running downward from center stitch line, slits to be in center of aparejo. In cutting slits be careful not to cut through center stitch line.

If using packing device cut two slits 1 inch long and three-sixteenths inch wide, counting  $4\frac{3}{4}$  inches from center seam of aparejo to center to slit and 1 inch from each edge

These are for the purpose to receive chock plates holding staples that receive the side plates of packing device, etc.

Chock plates to be  $1\frac{3}{4}$  inches square and one-eighth of an inch thick; corners to be rounded off. To secure chock plates to aparejo provide four holes three-sixteenths of an inch in diameter, one at each corner spaced equally distant, and five-sixteenths of an inch from outer edges.

These to receive copper rivets that secure chock plates to aparejo.

Next provide two holes three-fourths of an inch apart, counting from center of hole each way; there to be placed at center of chock plate and are for the purposes of receiving staples.

Staples to be made of 3/16-inch best steel rod, and

when shaped to have a depth of 1 inch. In shaping staples they must have uniform width of three-fourths of an inch from crown to base, counting from center to center of staple. On extremities of staples provide a shoulder of sufficient depth to receive the chock plate and to be securely riveted thereon.

Note.—For 62-inch aparejo the body pieces are cut 2 inches longer than that for a 60-inch aparejo.

For 58-inch aparejo the body pieces are cut the same length as that provided for the 60-inch, the boots being cut 24 inches long and 16 inches wide.

Of 50 aparejos make twenty-five 60 inches long and 24 inches wide, thirteen 62 inches long and 24 inches wide, and twelve 58 inches long and 24 inches wide.

Note.—In ordering 50 aparejos the proportion of sizes should be as noted above.

In width they must be uniformly 24 inches throughout their entire length; and collar with center seam must positively be in the center of the aparejo.

### THE CRUPPER

To be of good, solid, fair leather, tallow finish, sides to be of good spread, weighing from 12 to 14 pounds, and free from cuts and blemishes.

Standard size for cruppers to be 78 inches long and 12 inches wide. To form crupper cut two sections 39 inches long and 12 inches wide.

At heaviest end, counting  $3\frac{1}{2}$  inches from one corner, cut in 4 inches to form dock; now describe a cut upward, circling to within 24 inches of opposite end.

Now allow a space of 2 inches for dock and cut in 2 inches, and describe a cut downward, circling to within 24 inches of the opposite end.

Half the crupper is thus shaped. Cut a corresponding one and lap both, allowing 4 inches for upper surface of dock, lap to be sewed down in center with two seams one-half of an inch apart; length of seams 4 inches; before lapping ends shave down the under surface at ends.

For top lacing provide a strip of good, solid leather 30 inches long and 3 inches wide, shaped to extend

around dock to within 24 inches of each end; cut 2 more strips same width 26 inches long, lap 2 inches and sew down with two seams one-fourth of an inch from each edge.

For bottom facing provide two strips of good solid leather 37 inches long, conforming to the shape of lower edge of crupper; commencing at one end there must be a uniform width of 3 inches, extending 15 inches toward opposite end, then describe a cut, circling toward center of dock, greatest width to be 6 inches; to be sewed down three seams, outer seams to be one-fourth of an inch from outer edges, the third, or center seam, to extend from dock to within 24 inches of opposite end.



To form cover for dock, take a piece of good, solid leather 10 inches long and 7 inches wide doubled in center the long way, and at center of ends cut in 3 inches, at end of cut and in center, use a  $\frac{3}{8}$ -inch hand punch so that it will fit down into the dock, soak well, draw snug and sew down; shave off the under edges so as to leave it smooth on the animal's hips.

Leave  $1\frac{1}{2}$  inches for dock and leave one or both ends open to introduce the stuffing. Deer or antelope hair is best for the purpose.

Stuff and form the dock while the leather is soft.

In shaping the dock rub it on top as the stuffing is introduced, at the same time bringing the ends of the crupper together and bending the ends of the dock upward so as to shape the dock to the animal's tail, and the butt of the crupper to the animal's hips.

Lining for crupper to be of 28-inch No. 10 cotton duck, extending from dock to within 24 inches of end each way; in cutting allow for lap of 1 inch all around;

to be sewed down with slanting stitch spaced one-half inch on upper and under sides. When lining is in position the upper edge of the crupper on either side of dock, extending 10 inches each way, to be bound down with sheepskin.

In sewing the upper edge of top facing a space of 10 inches should be omitted to receive this binding, binding to be then sewed down in regular manner.

At each end of crupper five  $\frac{3}{8}$ -inch holes are punched, the first and fifth to be in center of top and bottom facings, the rest spaced equally distant between the first and fifth and 1 inch from ends. On top facing and in center four  $\frac{3}{8}$ -inch holes are punched, measuring for the first 24 inches from center of dock, and spaced equally distant to last hole on end of top facing.

Lacing for crupper to be of best latigo leather one-half inch wide and 7 feet long

Lacings to have a slit at heavy end  $1\frac{1}{2}$  inches long in center and three-fourths of an inch from end. These to be fastened at hole provided on end of top facing of crupper.

#### *THE APAREJO COVER OF SOBRE-JALMA*

To be made of No 4, 22-inch cotton duck. The canvas is cut 4 inches shorter than the length of the body of the aparejo. It is faced on both sides with leather 4 inches wide from end to end and 5 inches wide across ends. These facings when put on must be allowed to extend over the sides and ends of canvas so as to make the cover three-eighths inch wider and longer than the aparejo; to be sewed with seam at each edge. The sewing on end or bottom facings must extend to ends of facings.

The protecting sticks or shoes to be 21 inches long,  $2\frac{1}{2}$  inches wide, and three-fourths of an inch thick, taper the ends on one side to half the thickness at ends, extending  $5\frac{1}{2}$  inches toward center from each end, and taper on edges from center to a width of 1 inch at ends; to be placed in center of facings across ends.

In tapering sticks do not allow a ridge in center. The protecting sticks or shoes to be faced at each end, facing to be placed so as to leave an exposed surface of 10 inches wide in center; to be sewed down with two seams one-half inch apart.

Now punch two holes three-fourths of an inch from edge of center, in front and rear, and three-fourths of an inch apart. This to secure aparejo cover to aparejo.

If using packing device provide two strips of leather 15 inches long and one-half inch wide these to be placed at front and rear and in center of aparejo cover, counting from each edge  $1\frac{1}{4}$  inches, and to be sewed down with two seams 3 inches long and secured at each end of sewing by copper rivets. Now counting 5 inches each way from center of sobre-jalma at front and rear provide a slit 1 inch long and three-sixteenths of an inch wide, slits to be parallel with the center of width of sobre-jalma. These to receive staples that secure the side plates of packing device.

### *THE APAREJO CINCHA*

To be made of No. 4, 22-inch cotton duck. The canvas to be 8 inches longer than the aparejo for which intended, and folded so as to make two thicknesses 10 inches wide; the lap to be sewed together with two seams and to be considered the surface side.

For mountain battery service the canvas will be cut 10 inches longer than the aparejo for which intended.

One end of the cincha to be supplied with a section of  $\frac{5}{8}$ -inch gas pipe, flattened at ends and curved so as to take the place of a ring, to pass the latigo or tightening strap around; when shaped must be 1 inch less than the width of the cincha. Flattened ends to be provided with holes punched  $1\frac{1}{2}$  inches from ends, to receive No. 8 copper rivets to hold it in place. This iron is fastened to cincha by two pieces of good, solid leather, 11 inches long and  $5\frac{1}{2}$  inches wide and riveted to iron. Place one end of canvas between the folds of leather facing and sew down with three seams, two seams one-half inch apart, on outer edge, and one seam around edge of hole. This hole to be 3 inches wide and  $3\frac{1}{2}$  inches long, shaped half oval. The shape half oval to be up and down.

This for the latigo or tightening strap to pass through. The reverse end of cincha is faced with

leather  $8\frac{1}{2}$  inches on inside, 10 inches wide and 10 inches long, cut conical shape on outside. Fold  $1\frac{1}{2}$  inches from square end and lay into this fold a 5-16-inch iron rod 9 inches long; lay it over end of cincha and sew down with one seam across the end, so as to catch the short or under side of facing, and two seams one-half inch apart along the edge of conical facing. Care must be taken that the sewing extends to ends, so that the 5-16-inch iron rod will not escape.

Fifteen inches from strap or rod end of cincha sew on a round piece of leather 3 inches in diameter on outside of cincha; punch two  $\frac{3}{8}$ -inch holes, one inch apart in center. This to hold fastening, or finger loop,

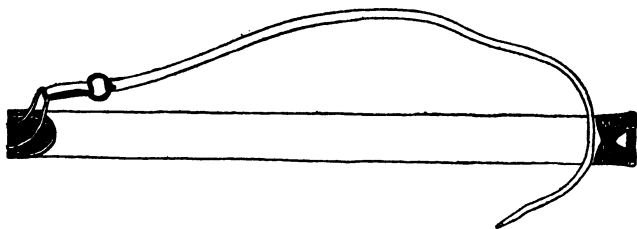

as it is termed, and should be of good, solid leather. Thong for fastening loop to be 12 inches long and one-half of an inch wide, of best latigo leather, secured underneath, allowing as much loop to extend on outside as possible. Its use is to hold end of latigo or tightening strap when the aparejo is cinched on the animal.

The latigo or tightening strap to be from 7 to 8 feet long; width,  $1\frac{3}{8}$  inches at heavy end and three-fourths of an inch at light end.

The rendering ring in heavy end of tightening or cincha strap to be of 3-inch breeching ring, dropped into a bight, lapped  $2\frac{1}{2}$  inches inward; drop into lap the 3-inch ring, double over so as to leave a space of three-fourths of an inch from end of strap to the inside of lap. This loop is for the lace string to pass through.

Rivet in center of folds and sew down two seams.

The lacing for fastening straps to cincha to be one-half inch wide and 6 feet long; to be of best latigo leather.

The conical facing to be provided with three  $\frac{3}{8}$ -inch holes, two 6 inches apart and one-half inch from rod, the third in center and 1 inch from top.

To fasten cincha and latigo strap with lacing, bring the ends together and pass through hole at center from underneath, allowing a loop of one-half inch to remain underneath, separate ends, and pass down through holes at end.

Take the folds of latigo, ring up, and pass the right end of lacing through loop from right to left and into left-hand hole in cincha from above, pulling sufficient through to pass into the loop in center underneath, about 6 inches.

Take the left-hand lacing and pass through loop from left to right; continue and finish as before.

### THE CORONA

To be three thicknesses of blanket; the first or top blanket to be of first-class kersey material, free from shoddy or any impure material; to be of uniform color, gray preferred, and two thicknesses of fair quality, together equaling the strength of the first or top blanket.

To be 2 inches wider and 10 inches shorter than the aparejo for which intended; to be faced through center from front to rear with kersey material contrasting in color with body 14 inches wide; to be sewed down with one seam on edges and one seam through center to first thickness or top blanket.

For border provide light canvas webbing of brown khaki color 3 inches wide, lapped under, underpinning all around, so as to leave a surface of 2 inches on top or outer surface of corona; to be sewed down with 2 seams, one-fourth of an inch from the inner edge for the first and  $1\frac{1}{2}$  inches for the second.

Center of one side of top blanket is provided with a numeral, 8 inches high, numbers running from 1 to 50, sewed down to first thickness or top blanket. Good tanned sheepskin is required for the purpose. The two thicknesses of underpinning to be basted down to first thickness or top blanket.



Sweat cloth to be of No. 10 28-inch cotton duck, one inch wider on sides and ends, lapped under to come flush with edge of corona all around; to be sewed with "T-stitch," the same under as well as over, three-fourths of an inch apart and three-fourths of an inch from edges. The stitch must lap on edge over all.

### *PACKERS' BLINDS*

To make a cup blind take a piece of good, solid leather, 26 inches long and  $6\frac{1}{2}$  inches wide; cut and shape to leave it 3 inches wide at ends and center and  $6\frac{1}{2}$  inches midway between ends and center.

Now leave a space of five-eighths of an inch at center of cup and cut out a piece on each side, V shape,  $1\frac{1}{2}$  inches at edges; on the under side channel cut and sew together to form cup.

Face edges with strap, three-fourths of an inch wide and long enough to come within 2 inches of ends; shave ends to slope and sew down with two seams.

Punch two holes three-fourths of an inch apart and three-fourths of an inch from ends; cut out between for tail thongs to pass through. For thongs cut a strip of best latigo leather five-eighths of an inch wide and 5 feet long; shave ends to slope and pass through slit at ends.

For end facings take a piece of leather  $6\frac{1}{2}$  inches square, double and shape to end; punch two holes in center of double three-fourths of an inch apart and cut out between; soak well and slip thongs through slit; draw up snug and sew down with one seam on edges. Thongs to be sewed down through center 9 inches from each end of blind, thongs to be lapped and riveted at end of sewing.

For thumb piece take a piece of leather 12 inches long and  $3\frac{1}{2}$  inches wide; punch and slit in 1 inch from edge and 3 inches from ends on each side. Lap the sides inward, so as to catch edges, and sew down with one seam. Draw it well together and cut ends, so as to shape in between straps; place in center of crown and sew down with one seam on edge, and rivet on each side of crown.

### **THE PACK COVER OR MANTA**

The *Pack Cover* should be made of fairly heavy duck (No. 4 cotton duck) and should be when finished 6 feet square.

It is used to gather into one pack a collection of small articles, to protect them from the elements in transit, from rough and frequent usage, and it adapts itself to any form or shape of equipment. Ordinarily it should be always used. A net of rope or rawhide is almost invariably used in South America.

For equipment that is constantly in use and that must be easily accessible while on the march the kyacks or alforjas are better.

These are nothing but great saddle bags of heavy canvas or leather and with inner and outer pockets, subdivisions, etc., to suit the individual taste, and protected with overlapping flaps and buckled straps. Boxes, specially and strongly made for such purposes, are also recommended for such frequent access when on the trail.

But for the main packing of staple equipment the pack cover is best.

It is also useful in emergencies to make a litter, or stretcher or travois.

### **LASH ROPE WITH CINCHA AND HOOK**

Lash rope, standard size to be nine-sixteenths or one-half inch best hand-laid manila, 50 feet long, provided with an eye at one end to receive lacing of cincha, the opposite end to be well wrapped or seized.

### **SLING ROPES**

To be made of  $\frac{3}{8}$ -inch best hand-laid manila, wrapped or seized at each end, and to be 30 feet long.

### **LAIR ROPES**

To be made of  $\frac{3}{8}$ -inch best hand-laid manila, to be provided with an eye at one end, the opposite end to be well wrapped or seized, and to be 30 feet long.

*HICKORY RIBS*

To be of sound second growth straight-grained hickory, free of knots or other blemishes; 23 inches long, 1 inch wide, and three-eighths of an inch thick for 60-inch aparejos; 24 inches long for 62-inch aparejos, and 22 inches long for 58-inch aparejos.

In a half set of nine ribs, the third has a taper of 8 inches at its upper end, thickness at end to be three-sixteenths of an inch; for the fourth, fifth, sixth, seventh, eighth, and ninth, successively, a gain of 2 inches in the taper is provided.

On one side at bottom and 2 inches therefrom, numerals indicating the size of the aparejo, with number of rib, will be stamped thereon, a hyphen or dash to be used in separating the number of ribs from the number of aparejo.

In numbering the set of nine ribs, commence with the two that are not tapered; these to be numbered 1 and 2 each.

Two half sets of nine ribs each comprise a complete set for one aparejo.

In lots of 50 sets, 25 to be 23 inches long; 13 to be 24 inches long, and 12 to be 22 inches long, respectively.

*HAY*

Hay to be free of joints, or what is known as "swamp" hay; that is, fine, soft, elastic hay, and for each aparejo 6 pounds will be considered sufficient.

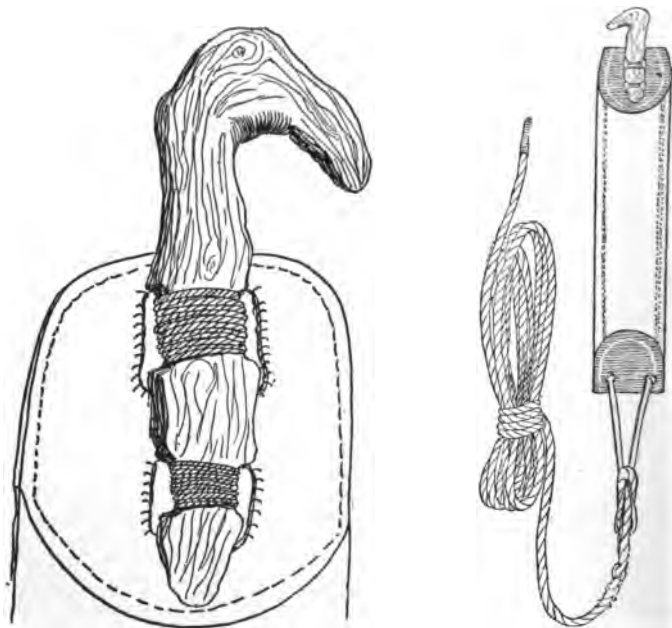

Lash Rope with belly band and wooden hook. The wooden hook is the crook of a tree whittled down to form.

Detail of wooden hook and method of fastening to belly band.

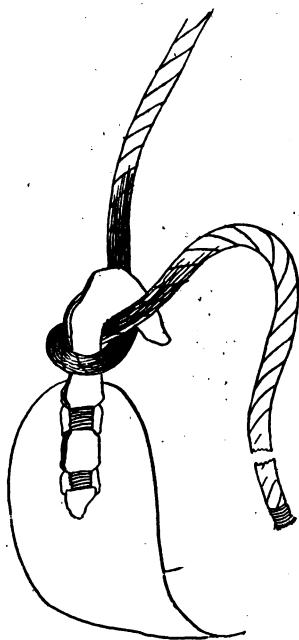

Blackwall hitch on wooden hook to hold turns of hitch in place temporarily.

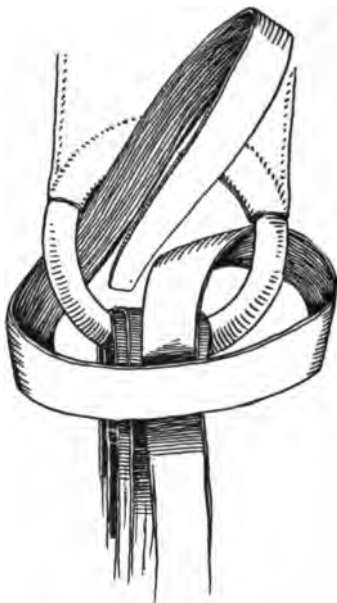

Fig. 1.

**TO FASTEN THE LATIGO**

The *Latigo* is the strap by which the girth or cincha of a saddle is made fast to a ring attached to the saddle or to the other end of a girth or cincha.

In cinching, the *Latigo* is passed through the ring from the outside through to the inside. Then down to the ring in which the *Latigo* itself is permanently attached; through that from the inside to the outside and up.

Then from the outside through the upper ring but passing under and out at the right of the ring.

Bring the strap around to the left horizontally and then pass it to the left around back of the ring and then out through the ring to the front.

The position of the *Latigo* is now shown in *Fig. 1*.

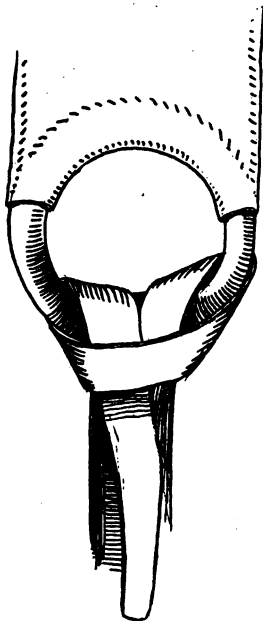

Fig. 2.

Pass the end of the Latigo down through the horizontal loop of strap on the outside. Cinch and pull the end tightly. This will hold.

The position of the Latigo is now as shown in *Fig. 2*.

## TO LAIR UP A PACK

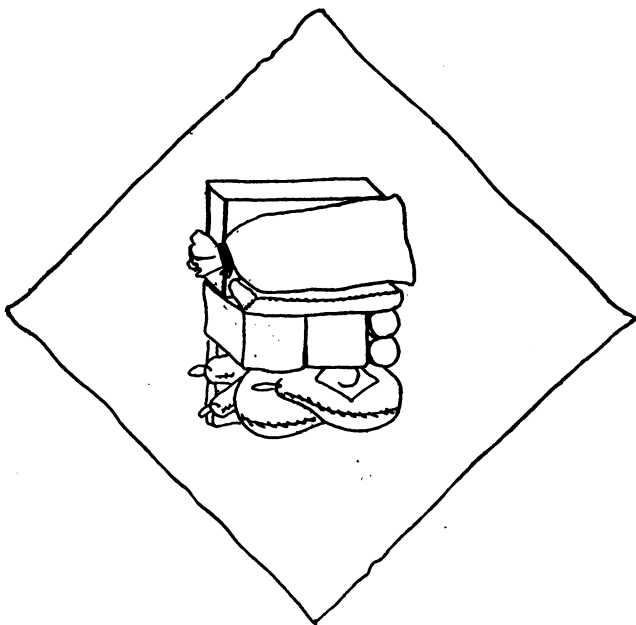

Fig. 1.

*The cargo being weighed and balanced to lair up a pack:.....*

*Fig. 1.* The *Packer* spreads out a Pack Cover on the ground. On it he arranges the weighed cargo for one pack in such a manner that it shall be squared—as nearly as possible at the corners and ends—and its sides shall be diagonal to the sides of the pack cover. (*Fig. 1.* suggests this process.)



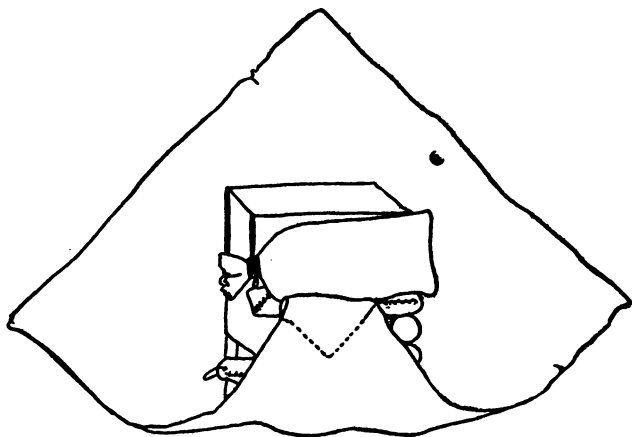

Fig. 2.

*Fig. 2.* The Packer then folds one corner of the pack cover over the pack, drawing it smooth and as free as possible from folds, and then turning under the corner of the pack cover holds it in place with his knee.

The position of the pack cover is now shown in *Fig. 2.*

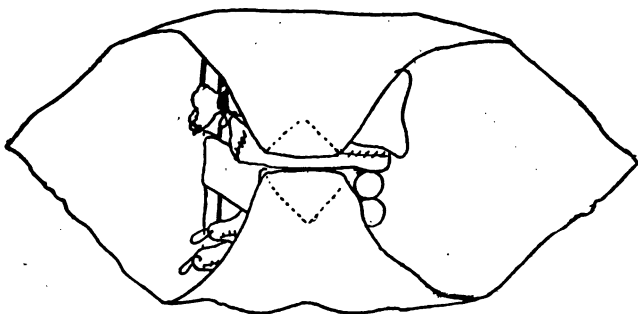

Fig. 3.

*Fig. 3.* The Packer then folds over the opposite corner of the pack cover, keeping it smooth as possible, turns under the corner and holds it down on the pack. If possible it should overlap the first corner of the pack cover. The position of the pack cover is now shown in *Fig. 3.*

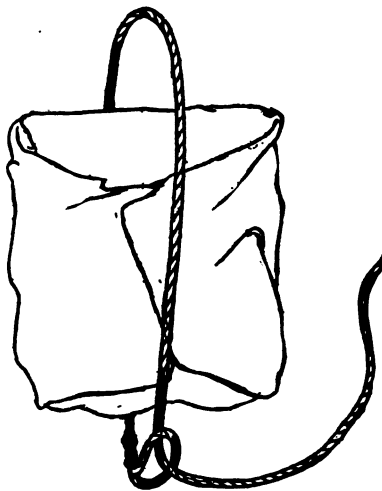

Fig. 4.

**Fig. 4.** Both of the other ends of the pack cover are now brought up and over the pack in the same manner as indicated for the first corners. The pack cover should be kept as smooth as possible and neat at the corners.

The Packer now slips under the pack the lair rope, its length running with the long axis of the pack, or down the center if it be a square pack.

He passes the end of the lair rope through the loop at the other end. (If no loop is already spliced in the lair rope a bowline will do as well.)

The position of the pack cover and lair rope is now as shown in *Fig. 4*.

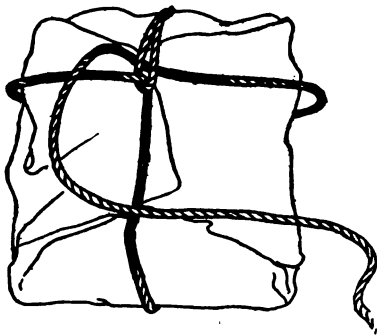

Fig. 5.

*Fig. 5.* The Packer passes the end of the lair rope to the left making a complete turn around the pack at its upper end and then passes the end under the loop and out between the end of the pack and first turn. (With some packs it is also necessary to take a half turn with the lair rope on the other side of the pack around the standing part. Judgment alone can decide this.)

The position of the pack cover and lair rope is now as shown in *Fig. 5*.

*Fig. 6.* The Packer now brings the lair rope down on the other end of the pack making a half hitch around the pack. He passes the end of the rope around the pack, lengthwise, and following the first loop around the pack, back to the spliced

loop. (The same remark applies as to the necessity of taking a half turn around the standing part on the back of the pack. If so a half hitch cannot

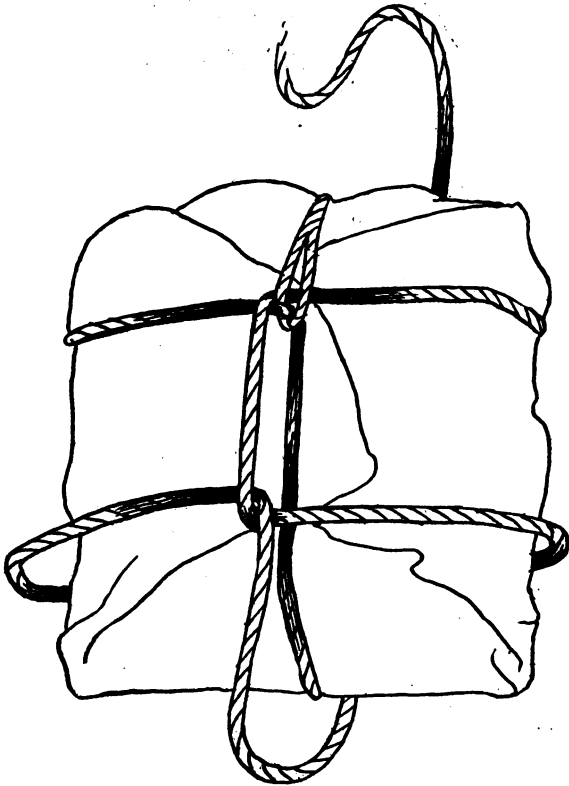

Fig. 6.

be used but the lair rope must be followed round, turn by turn.)

The position of the pack cover and lair rope is now as shown in Fig. 6.

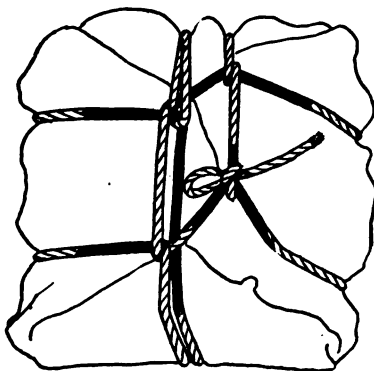

Fig. 7.

**Fig. 7.** The Packer brings out the end of the lair rope a little to one side of the loop and takes a half turn around the first transverse rope (first transverse turn shown in *Fig. 5*) in such a manner that the lair rope leads forward to the second transverse turn (second transverse turn shown in *Fig. 6*.) The Packer now cinches the pack—if he has not kept the lair rope taut as he went—and makes fast to the second transverse turn.

The pack and lair rope are now as shown in *Fig. 7*.  
Note.—A slip knot is generally amply secure for the lair rope, it can be undone in rainy weather when wet. A hard knot is exceptional in any of the steps or phases of pack transportation, and only when there is a special reason therefor.

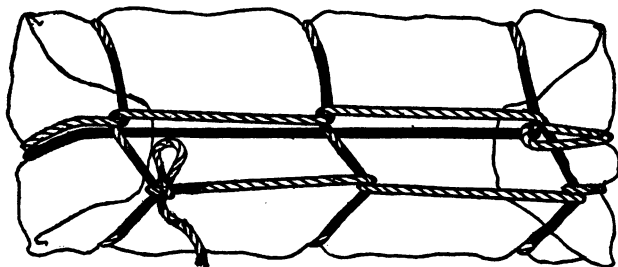

Fig. 8.

**Fig. 8.** If a longer pack is required it should be laired up as just described but with 3 transverse turns instead of 2.  
It is shown in *Fig. 8*.

### *SLINGING THE CARGO*

Normally two men make the loads, sling the cargo and throw the hitch. All of the operations can be done by one man acting entirely alone as described elsewhere.

This is described for two packers, *No. 1* and *No. 2* as they are designated for convenience. *No. 1* is in charge. He takes position on the near side of the mule while *No. 2* takes position on the off side and opposite the aparejo.

*The loads being balanced, to sling cargo*

*Fig. 1.* *No. 1* takes the sling rope, forms a bight with the apex at about the middle of the rope. He then throws it across the aparejo to *No. 2*; he then sees that the two parts on his side are properly separated according to the size of the loads. *No. 2* adjusts the bight on the far side according to the size or shape of the load (making a larger



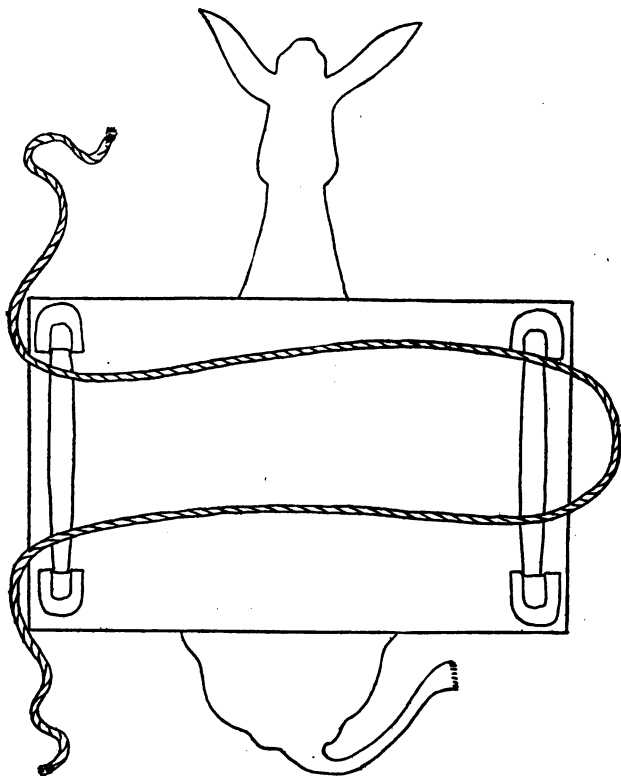

Fig. 1.

bight, or passing back some of the bight if it is too large or hangs too low.

The position of the sling rope is now as indicated in Fig. 1.

Fig. 2. No. 1 lifts the one load to the ridge of the aparejo where he balances it until he hears No. 2 call:

"Ease away."

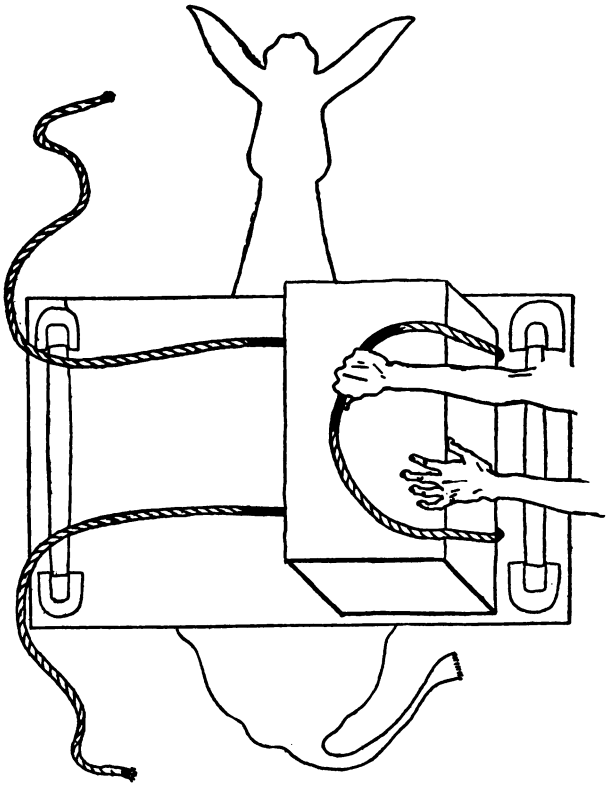

Fig. 2.

At this *No. 1* lets go and picks up the second load. *No. 2* balances the load on the ridge of the aparejo with one hand while with the other he lifts the bight of the sling rope and lifts it up and against the load forming a sling. He holds the load slightly balanced on the off side of the aparejo. The position of the sling and load is now as indicated in *Fig. 2*.

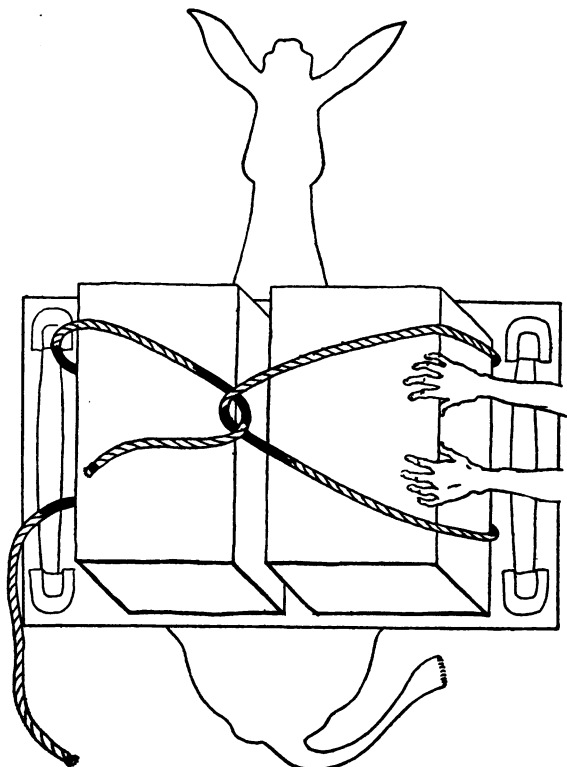

Fig. 3.

*Fig. 3.* No. 1 now lifts the second load into position as high on the aparejo as he conveniently can. He commands:

"Rope."

No. 2 lifts the bight and pushes it towards him.

No. 1 holds his load in place an instant with his hand or shoulder (or if the load be too heavy or

awkward by balancing it a second on top of the mule while *No. 2* holds the full weight from his side) and seizes the forward free end of the sling rope.

This rope *No. 1* passes through the bight passed him—or as it is being held for him—by *No. 2*. Holding this one end taut he seizes the rear end of the sling rope and brings the two ends together. The loads now rest in their slings with slight effort while *No. 1* ties the two ends in a slip knot. The position of the cargo and sling rope and the duty of *No. 2* is now as indicated in *Fig. 3*.

*Fig. 4.* The sling should be tightened so that both loads—if they are the ordinary, normal loads—ride rather high, that is, the lower inside angles or sides should about meet on the ridge or the center of the aparejo.

The loads should be perfectly balanced with an even weight or strain on each side.

A little lifting and shifting, without tightening or loosening the sling rope is often necessary. Actual practice alone can determine this point. It is *No. 1* who takes charge of this.

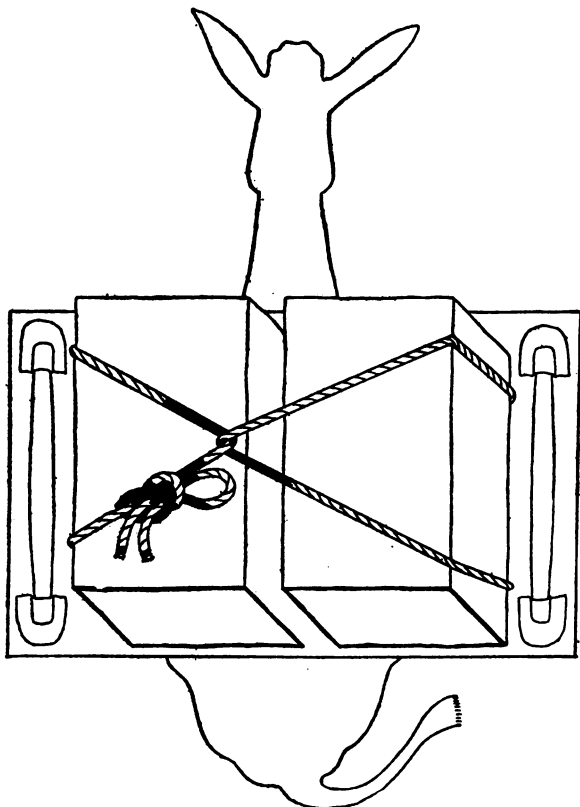

Fig. 4.

If he wishes to adjust, he commands:  
*"Brake."*

At this *No. 2* lifts the off load and assists in placing the loads according to the suggestions of *No. 1*. The cargo and sling rope are now in the position as indicated in *Fig. 4*.

**THE ONE-MAN CARGO SLING**

*The packs being balanced, to sling the cargo with but one packer:*

**Fig. 1.** The Packer first loops the lash rope over the sobre-jalma in such a manner that one bight falls on the off side and half on the sobre-jalma forward and the free end comes back across the mule's neck to the near side again.

The second and rear bight passes in a like manner across the rear of the sobre-jalma with the free end returning and lying across the mule's rump.

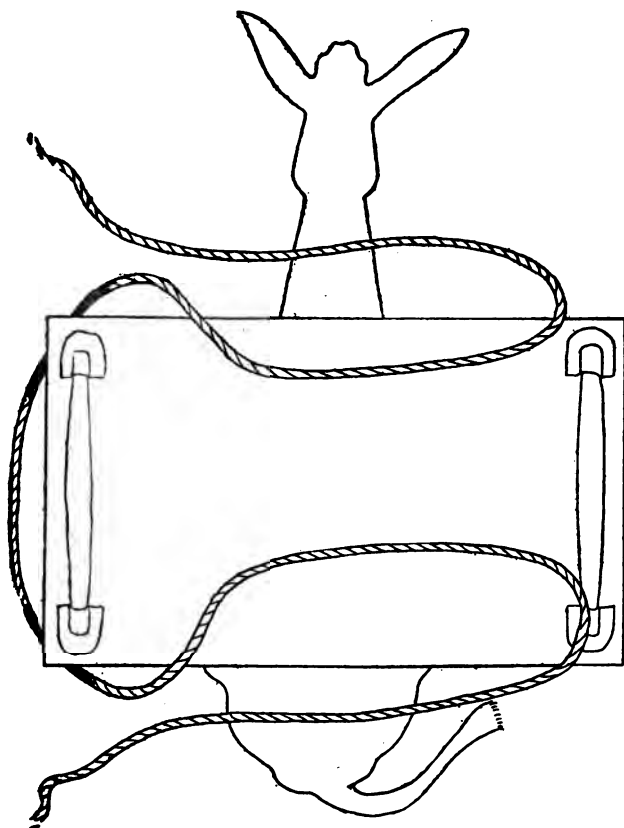

Fig. 1.

The middle section between both bights is caught *under* both corners of the sobre-jalma on the near side.

The position of the lash rope is now as indicated in *Fig. 1*.

## HORSE PACKING

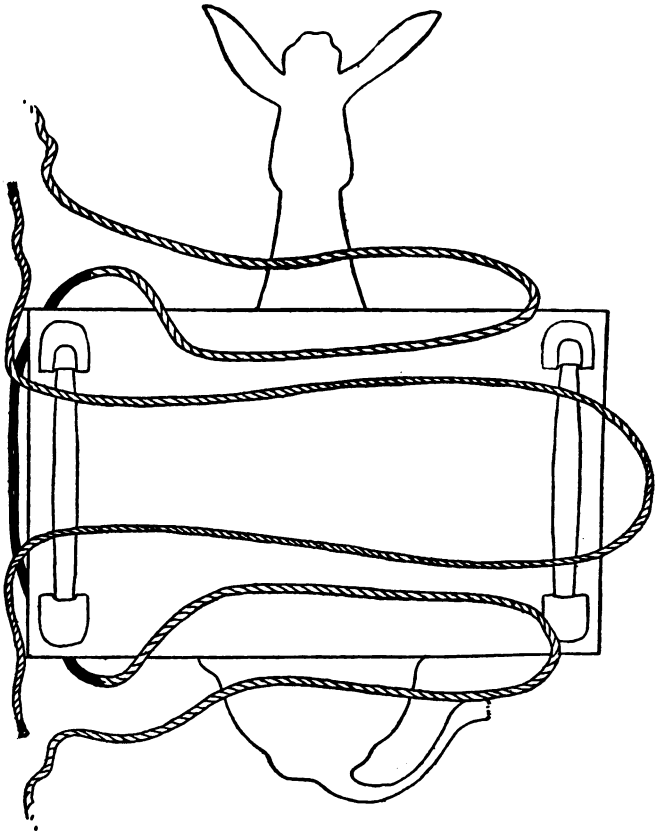

Fig. 2.

*Fig. 2.* The *Packer* now forms a bight with the *sling rope* and passes it across the *sobre-jalma* in the same manner as though it was to be laid with the help of another man. The position of the lash and sling ropes is now as indicated in *Fig. 2.*



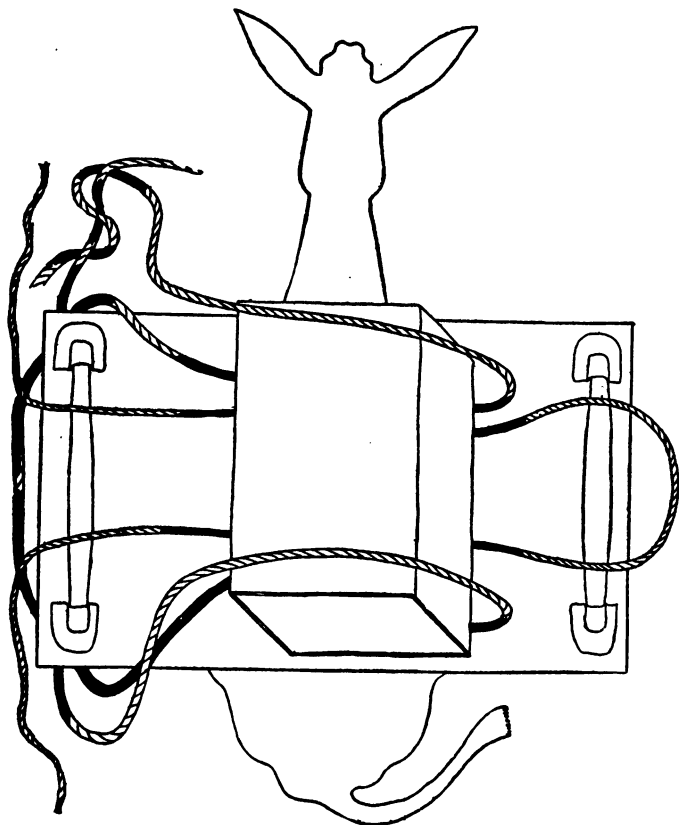

Fig. 3.

*Fig. 3. The Packer now lifts the one load and balances it on the top of the sobre-jalma. (Fig. 3.)*

*Holding it in place with the left hand he takes the free end of the lash rope that lies to the rear and throws it forward and over the load.*

*Balancing the load for a second now with his right*

*hand* he takes the free end of the lash rope that lies forward and throws it to the rear and over the load.

He now reaches and brings forward the free end of the rear lash rope, passing it well *under* the *sobre-jalma*, and brings it forward and up from under the *sobre-jalma*.

Holding both free ends in one hand, he takes up slack on both bights until the load lies lightly in them. He determines this by gently working the load off the middle ridge of the *sobre-jalma* so that it falls of its own weight over on the off side. It should remain well up.

The *Packer* now ties the two free ends in a slip-knot. The position of the load and lash rope is now as indicated in *Fig. 3*, except that the load is still balanced at the moment in the diagram and has not settled into the bights or slings.

*Fig. 4.* The *Packer* now passes to the off side of the mule and throws the bight of the *sling rope* back across the off side load over to the rear side.

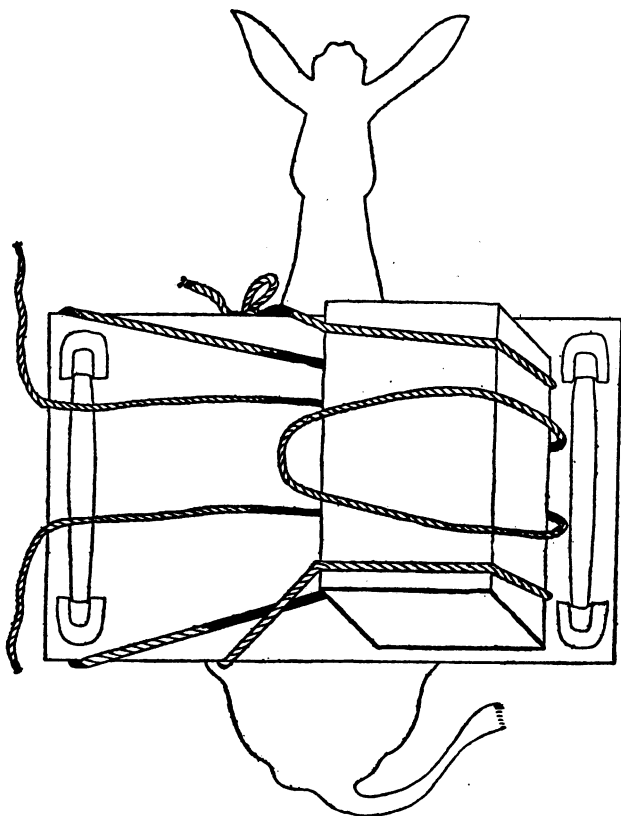

Fig. 4.

The position of the lash and sling ropes is now as indicated in Fig. 4.

Fig. 5. Passing to the near side again the *Packer* now lifts the near load into position as described for slinging cargo with two men. He takes the free

## HORSE PACKING

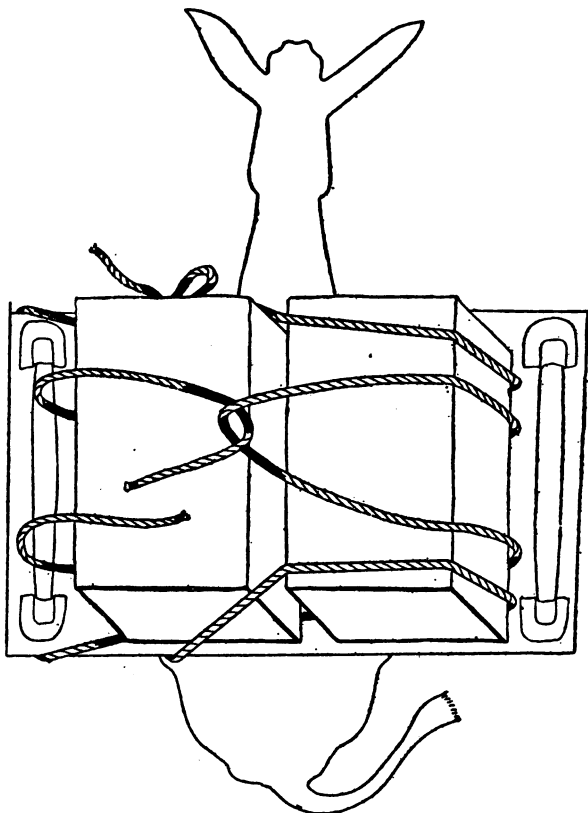

Fig. 5.

end of the forward part of the sling rope, passes it up and through the bight in the sling rope and makes both ends of the sling rope fast with a slip knot.

The position of the lash rope, sling rope and cargo is now as indicated in Fig. 5.

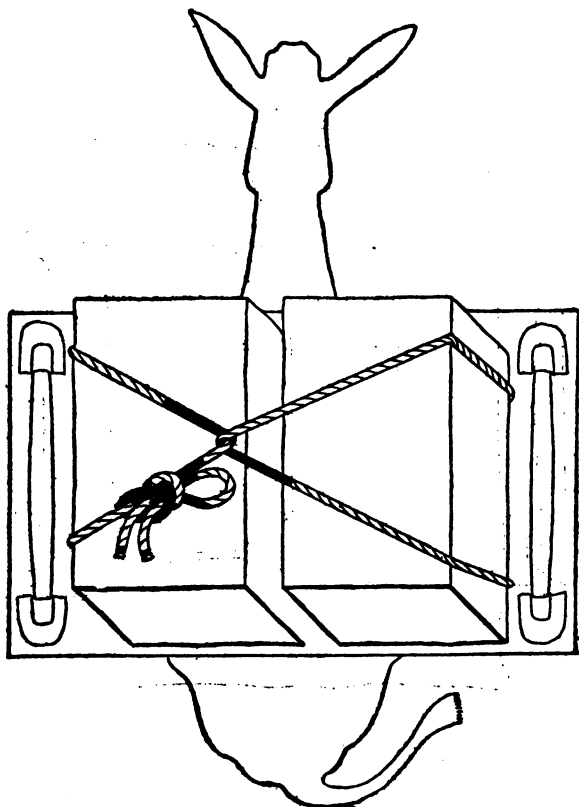
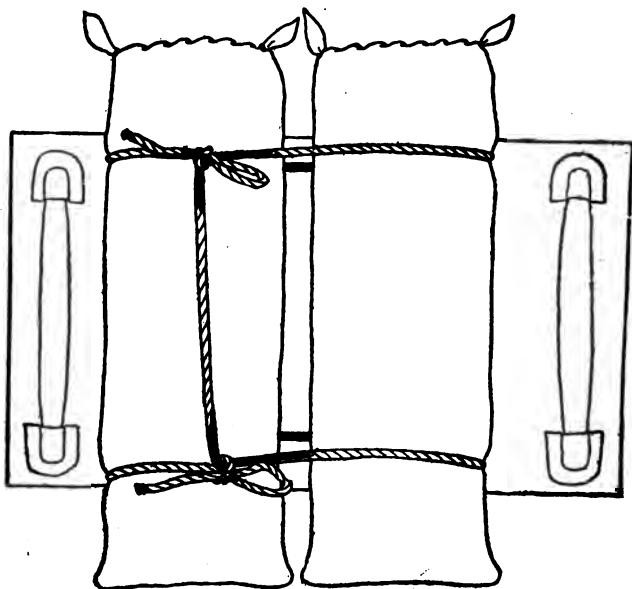

Fig. 6

*Fig. 6.* The *Packer* casts off the lash rope and the cargo is now slung. The position of the cargo and sling is now indicated in *Fig. 6*.

The cargo is worked and adjusted into position now in the same manner as described for two men, except, of course, that the one man passes from side to side as he lifts and tests the cargo adjustment.



### *DOUBLE SLING*

This is used for long packs.

The sling rope is laid as for the ordinary sling except that the bight is spread as far apart as possible.

The ends of the sling are tied separately to the forward and rear parts of the sling rope as shown in the diagram.

## CROSS SLING

This sling is used when a *Top Load* is to be packed.

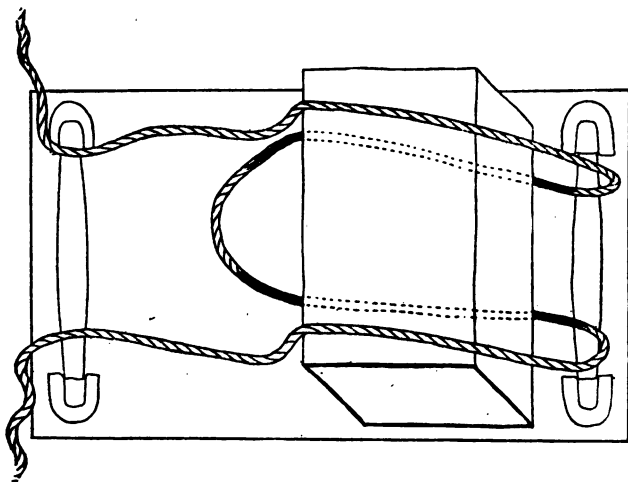

Fig. 1.

*The packs being balanced to load them with the Cross Sling:*

*Fig. 1. No. 1. takes the sling rope at the middle and throws both ends across the mule to No. 2. No. 1 holds sufficient of the bight of the sling rope so that it will come about to the top of the off load. No. 2 arranges the ends thrown to him at the proper distance for the pack and dropping to the ground parallel with the sides of the sobre-jalma. He then lifts the off pack in place, holds it there while he brings up the ends of the two ropes and throws them, over the off pack, back to No. 1. The position of the sling rope is now as shown in Fig. 1.*

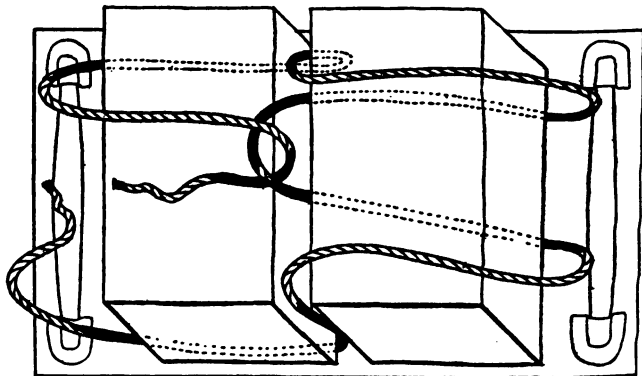

Fig. 2.

*Fig. 2.* No. 1 now lifts the bight and hands it to No. 2 who holds it against his pack.

No. 1 now lifts his near pack in place on the two ropes passed back to him by No. 2. He brings the forward end of the sling rope through the bight of rope held by No. 2 for him. He then brings up the rear end of the sling rope and ties it with the forward end.

The position of the sling rope is now as shown in Fig. 2.



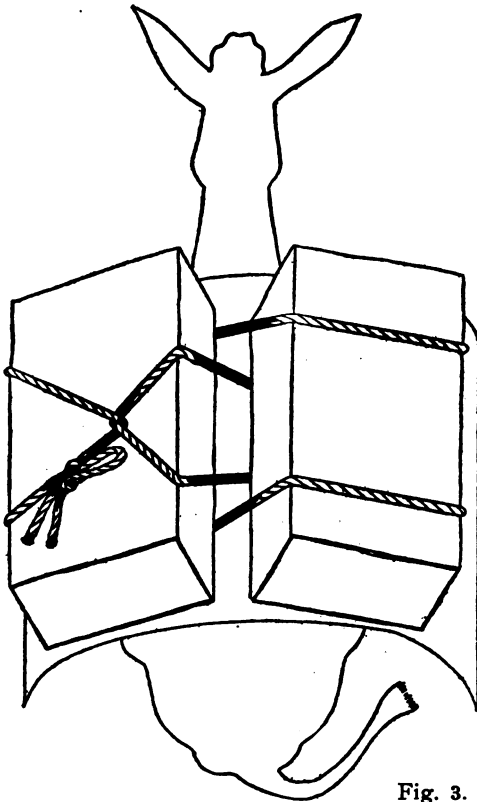

Fig. 3.

*Fig. 3.* The sling is now drawn taut and the packs shifted into position. In order to more clearly show the effect of this sling, the diagram of *Fig. 3* has been given a slightly more realistic perspective. It shows the manner in which the top load may be placed without interference with the sling ropes.

*Note.*—A top load should always bear or rest evenly on the side packs.

### *SINGLE DIAMOND HITCH*

This hitch is the most important hitch in pack animal transportation. With trifling variations of detail, it is found all over the United States as far as the Arctic Circle and throughout Central and South America wherever mules or burros are used for packing. It is the one best all-around hitch. To avoid confusion in the diagrams, the sling ropes are not shown.

#### *The Load Being Balanced and Slung to Throw the Single Diamond Hitch*

*Fig. 1.* The plan of the mule and the pack saddle, as if one were looking down upon it, ready to receive the cargo. It is drawn in an arbitrary manner to simplify the succession of phases as the hitch progresses.

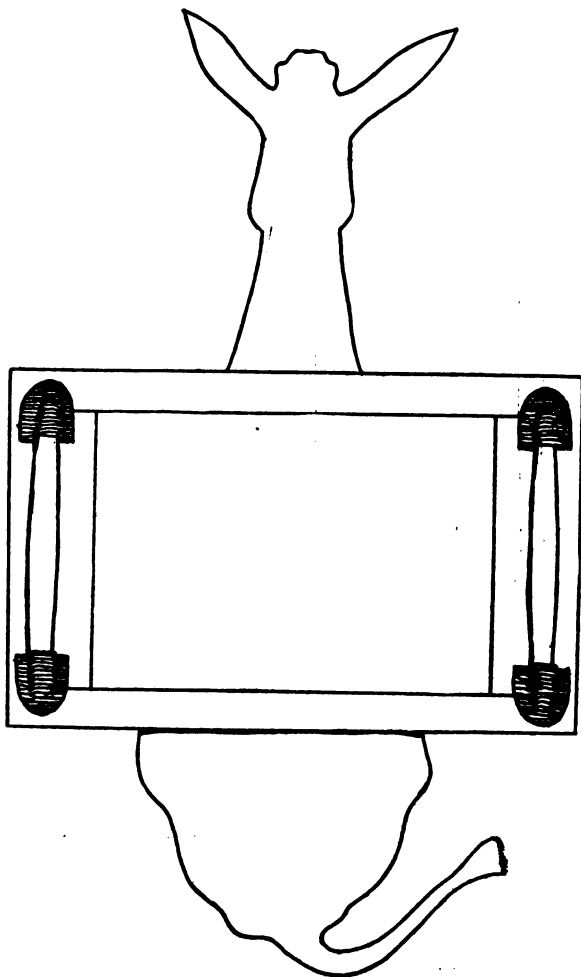

Fig. 1.

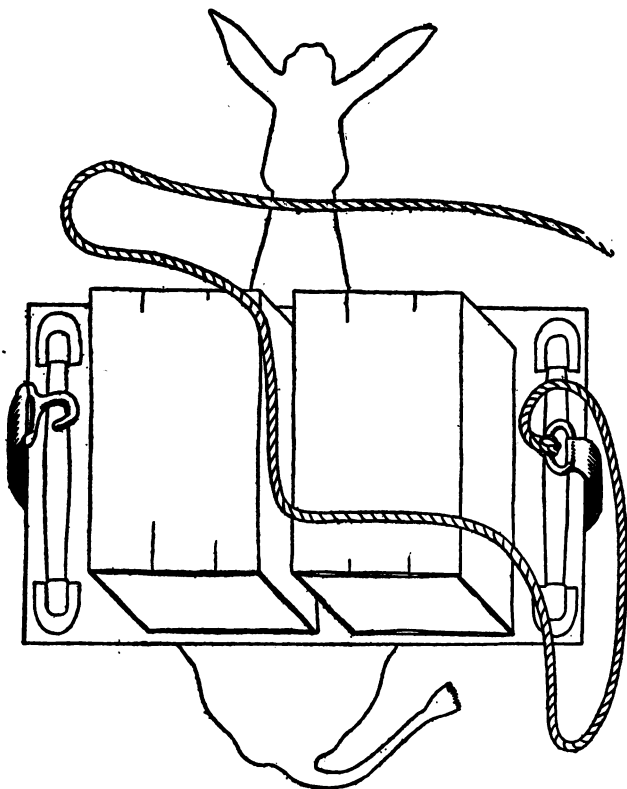

Fig. 2.

*Fig. 2.* No. 2 passes the cincha and hook under the belly of the mule to No. 1 who grasps the hook. No. 2 then reserves a good sized bight next to the cincha of the lash rope, throws the free part forward across the mule's neck, allowing the free end of the lash rope to fall down still on his, the off side.

*No. 2* now arranges the rear bight so that it will lie on the rear part of the off load, drop in between the cargoes, along the backbone of the aparejo. *No. 1* assists from his side in so laying the lash rope and seeing that it passes over and rests on the forward part of the near load. The position of the lash rope is now as shown in *Fig. 2*.

*Fig. 3.* *No. 2* now takes the bight next to the cincha (the standing part of the rope) and throws across to *No. 1* with a twist of the wrist.

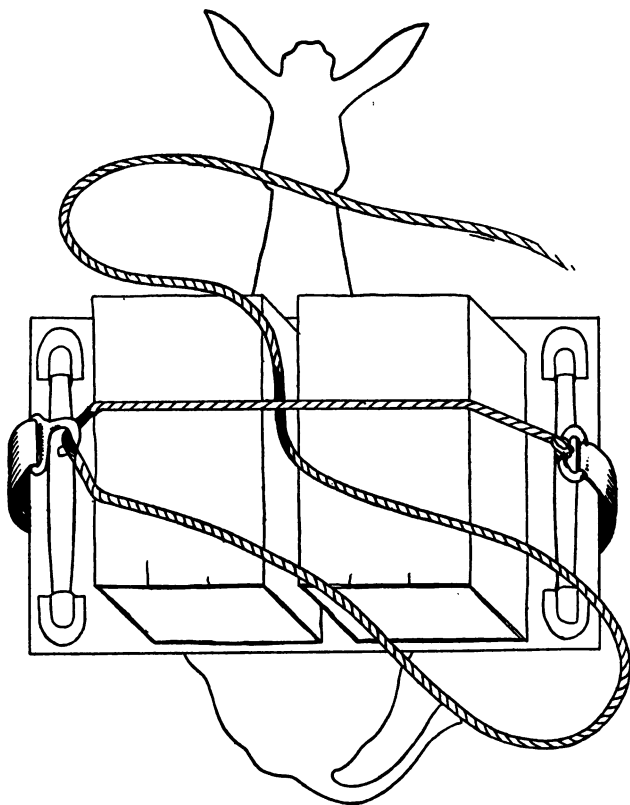

Fig. 3.

*No. 1* seizes it and engages the standing part of the bight with the hook of the cincha on his side. He then pulls up the slack lightly. The position of the lash rope is now as indicated in *Fig. 3*.

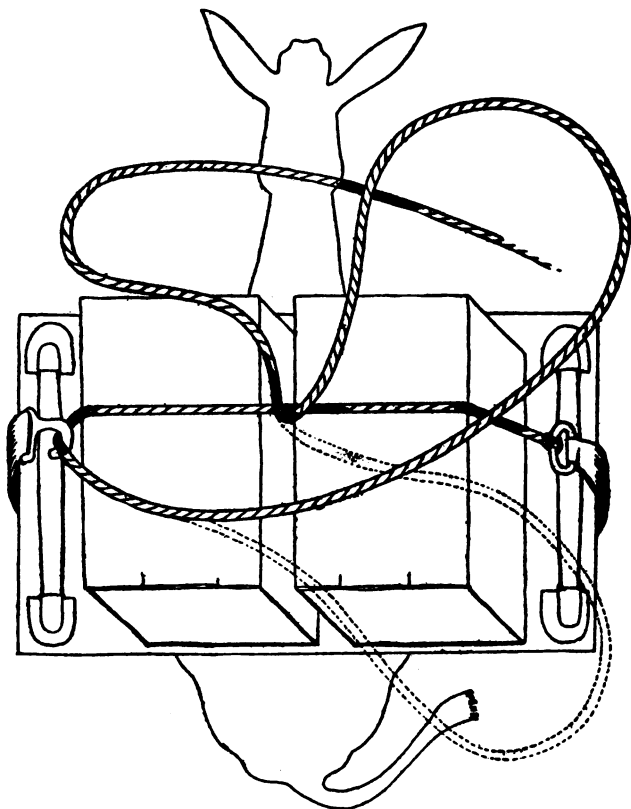

Fig. 4.

*Fig. 4.* No. 1 then throws his part of the bight forward, No. 2 at the same time on the off side assisting and throwing the bight forward and over the standing part of the lash rope. The position of the lash rope is now as shown in *Fig. 4.*

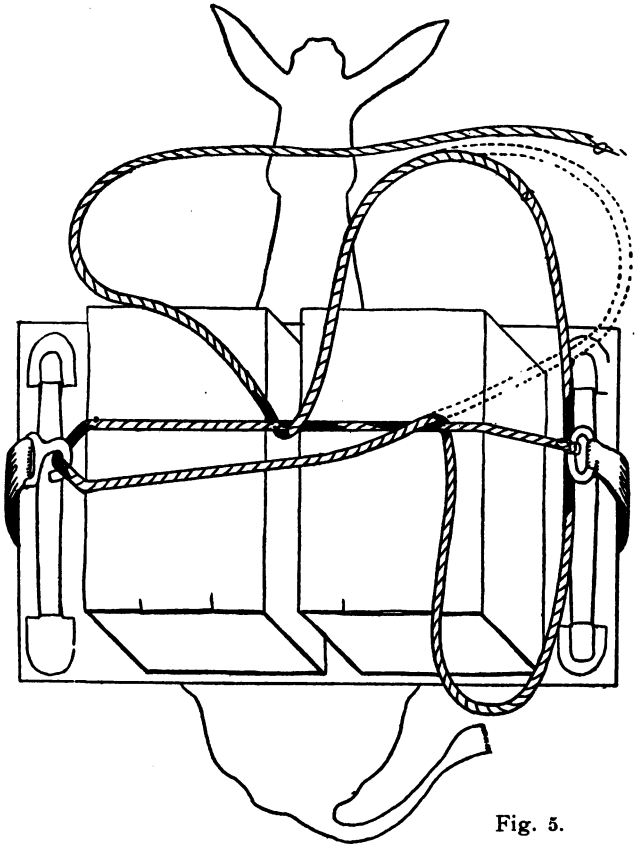

Fig. 5.

*Fig. 5.* No. 2 carries the bight or loop forward of the off cargo so that it will fall forward and around the off load and then brings the bight back and *under* the standing part of the lash rope. The position of the lash rope is now as shown in *Fig. 5.*



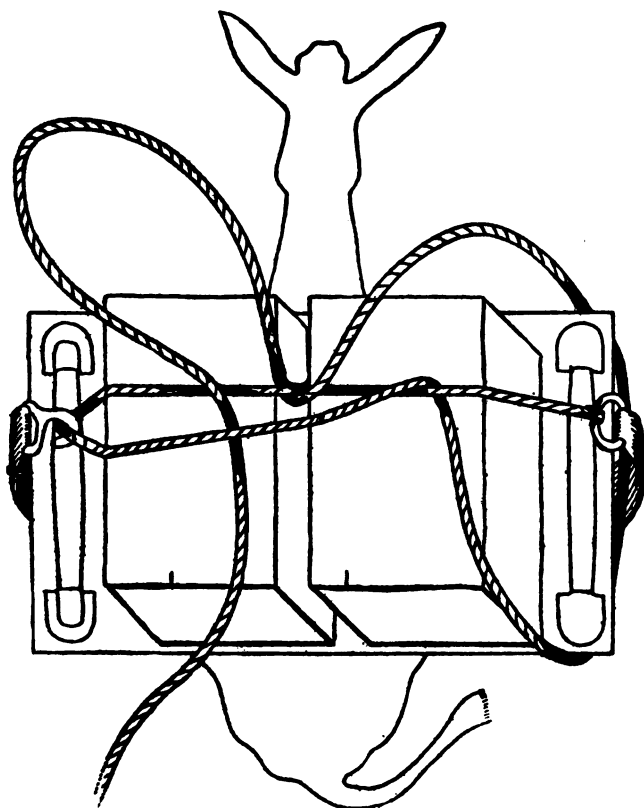

Fig. 6.

*Fig. 6.* No. 2 loops this bight over and down the rear of the off cargo and under the rear corner of the sobre-jalma. He then brings the rope of the loop forward, under the sobre-jalma and up and out of its forward corner.

*No. 2* then sees that the lash rope falls securely over the forward part of the off cargo and that its loop at the standing part is in or between the center on the load. He takes up slack as he goes but without hauling tight.

*No. 2* then calls:

**"Take."**

At this *No. 1* takes up the last rope on his side where it passes out under the standing part at the center of the load and forms a bight that will loop around the near forward corner of the cargo.

*No. 1* then passes the free end of the lash rope over the standing part and under the running part at or near the center of the cargo.

The position of the lash rope is now as shown in *Fig. 6*.

*Fig. 7.* *No. 1* now takes the forward loop he has just made and passes it over the near forward corner of the cargo and down under the near forward corner of the sobre-jalma.

*No. 1* now passes the loop along to the rear, bringing it up and around the near rear corner of the

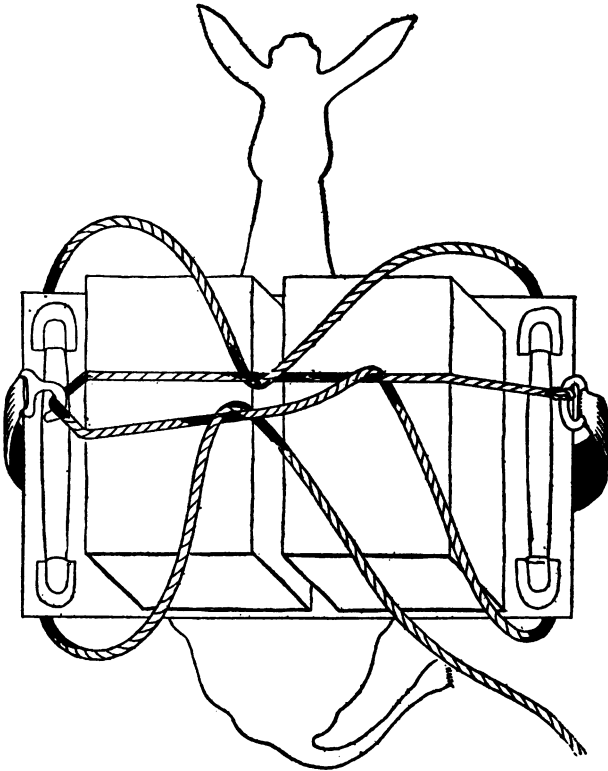

Fig. 7

sobre-jalma and cargo, lightly taking up the slack. *No. 1* then calls:

"Take."

and throws the free end of the lash rope over and across the rear of the mule to *No. 2*.

The position of the lash rope is now as shown in *Fig. 7*.

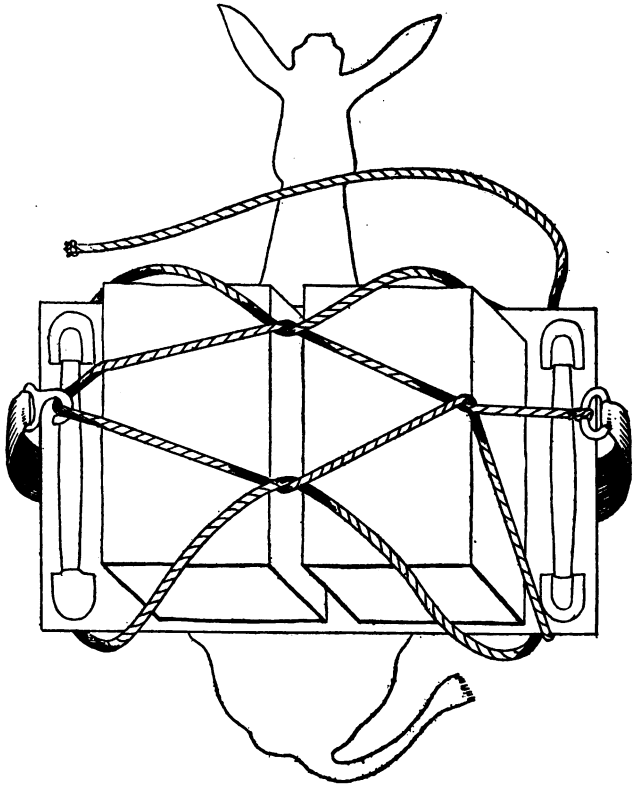

Fig. 8

*Fig. 8.* *No. 2* now grasps the free end of the lash rope thrown him and passes it under the *sobre-jalma* and forward where he throws it across the mule's neck.

The hitch is now ready to tighten. To indicate this, *No. 2* calls:

"Ready."

At this *No. 1* commands:

"Cinch."

At the same time he hauls taut on the running part of the lash rope where it comes out of the hook.

*No. 2* on his side also grasps the same rope and hauls.

(Note.—This hauling is done in the most convenient way, care being taken to bring the strain on the rope and not to merely push and haul the animal off his balance.)

*No. 1* and *No. 2* working together, each on his own side of the animal, take up the slack and haul tight in similar manner to that in which they progressed as they made the hitch.

*No. 2* when he again reaches the forward end of the off load and the hitch is tight, calls:

*"Take it all."*

At the same time throwing the free end with all the slack across the top of the load to *No. 1*.

The position of the lash rope is now as shown in *Fig. 8*.

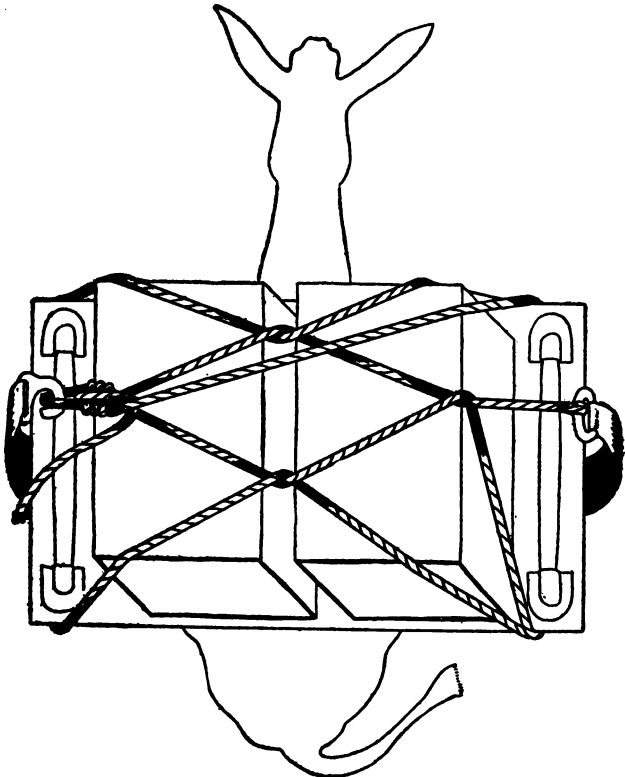
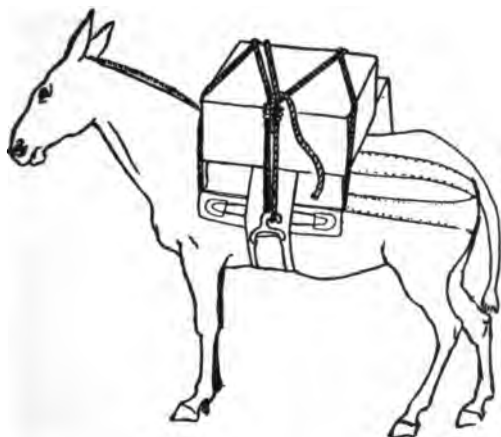

Fig. 9

*Fig. 9.* This shows the Single Diamond Hitch tightened and tied. The diamond by which it gets its name appears distinctly. There are various methods of making fast, a few turns and a slip knot being most often used.



**Fig. 10.** This shows the near and off side views of the Single Diamond Hitch.

*To avoid confusion in the diagrams the sling ropes are not shown.*

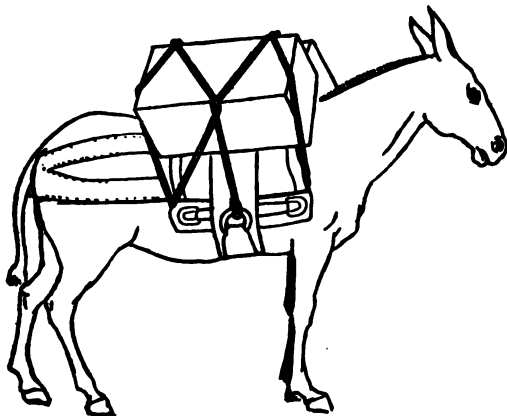

### *DOUBLE DIAMOND HITCH*

This hitch is used when there is a riding or striding load placed above the balanced load; especially if the riding load be a keg, a box or some awkward package. The *double diamond* hitch is best when the nature of the cargo requires more binding points than are possible with the more open *single diamond* hitch.

For a riding load the special Cross Sling *must* be used. (See page 75.)

*To avoid confusion in the diagrams the sling ropes are not shown.*

*The load being balanced and slung to throw the double diamond hitch:*

*Fig. 1. The near Packer, No. 1, throws the lash rope across the cargo, with the free end toward the mule's head and with a long loop at the rear. A shorter*



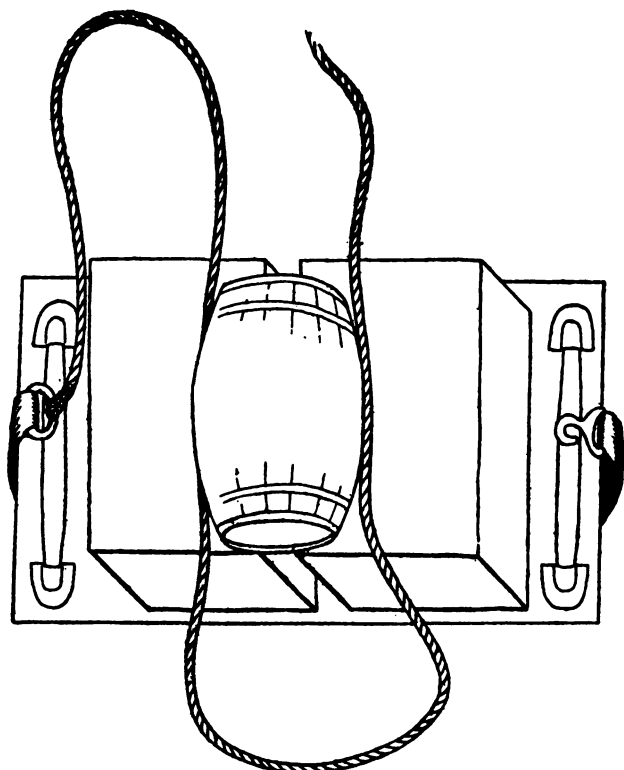

Fig. 1

loop is run forward on the near side of the cargo and *No. 1* then passes the *hook end* of the *cincha* underneath the mule to *No. 2*, who grasps it at the command:  
"Take."

The position of the lash rope is now as indicated in *Fig. 1*.

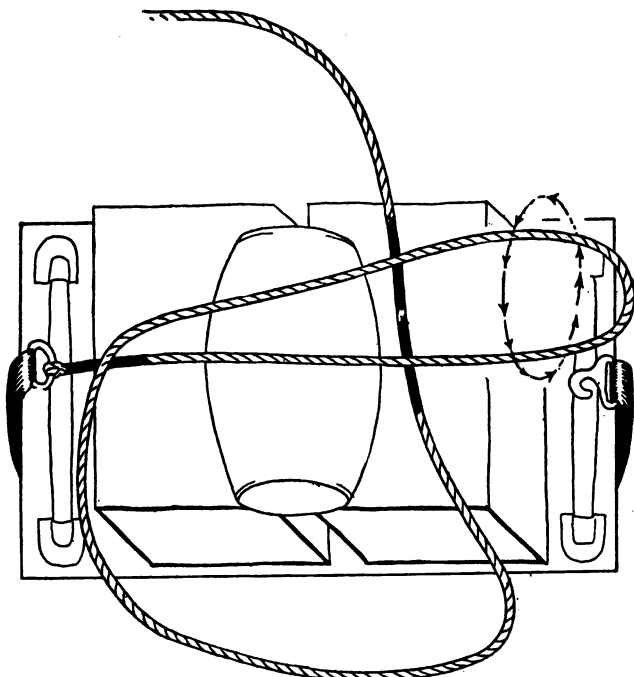

Fig. 2

**Fig. 2.** *No. 1* now throws the forward loop across the cargo in such a manner that the standing part of the loop comes underneath at the same time giving the command: "Ready."

*No. 2* grasps the loop and twists it one full turn to the left as indicated by the dotted line and arrows (Fig. 2) and bringing the center of the twist at the apex of the riding load.

The position of the lash rope is now as indicated in Fig. 2, (except that the twist has not yet been made).

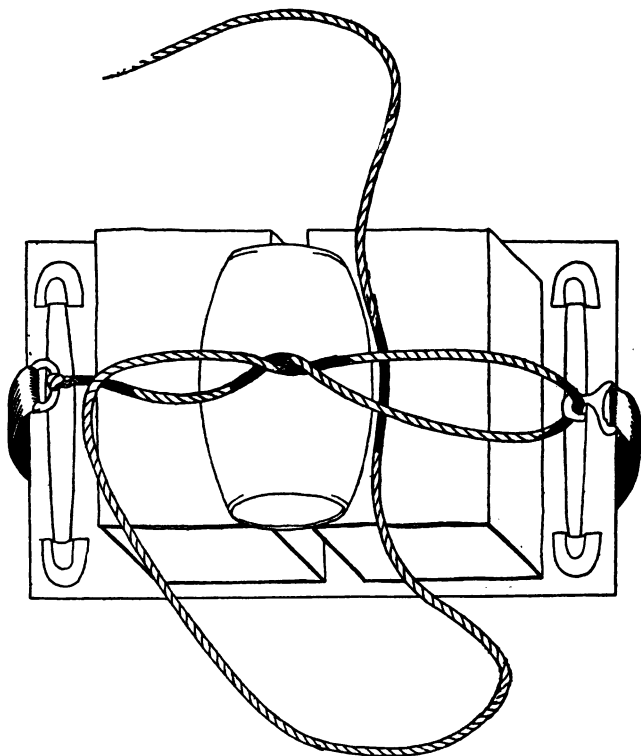

Fig. 3

*Fig. 3.* No. 2 then slips the loop over the hook and calls: "Heave."

No. 1 takes in the useless slack of the loop but without hauling the rope tight; it should lie loose but without danger of slipping off the riding load.

The position of the lash rope is now as indicated in Fig. 3."

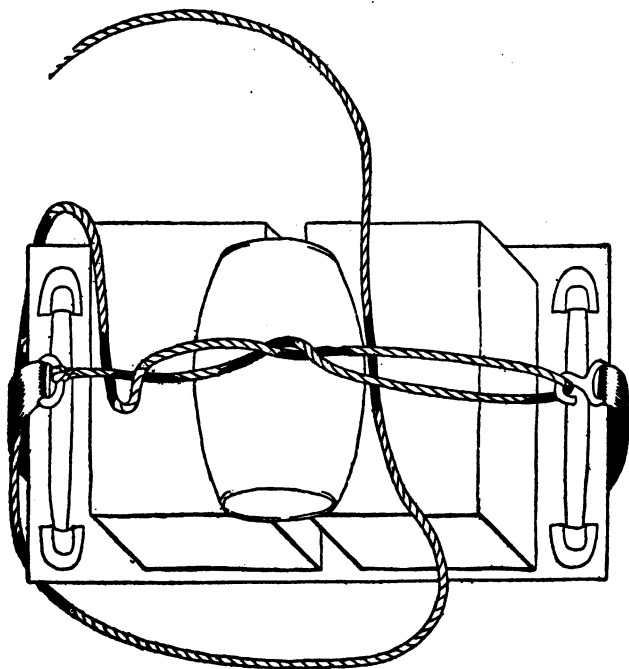

Fig. 4

**Fig. 4** *No. 1* now passes a portion of the rear loop forward and *through* the standing part of the lash rope, taking it forward and *over the near forward corner* of the cargo, down and under the near forward corner of the sobre-jalma. It will fall easily inside the sobre-jalma and under the near rear corner of the sobre-jalma. The position of the lash rope is now as indicated in **Fig. 4**.

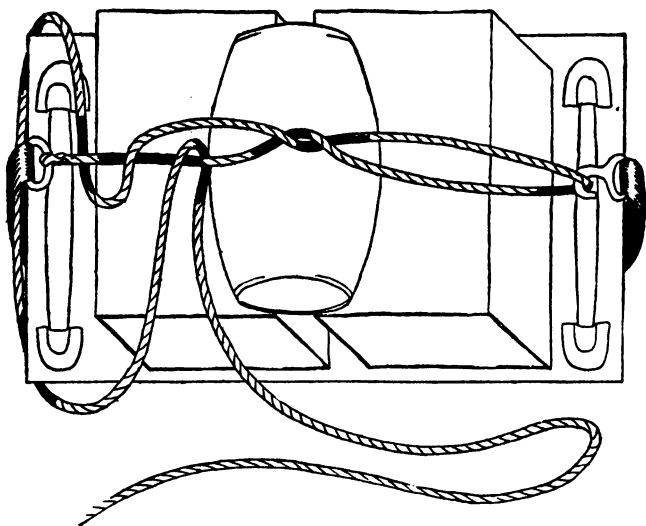

Fig. 5

*Fig. 5.* No. 1 then takes the end of the lash rope and passes it *over and down* between the two central ropes at a point between the riding load and the near side load. He then commands:

*"Ready"*

and throws the lash rope across the rear of the mule to No. 2.

The position of the lash rope is now indicated by *Fig. 5.*

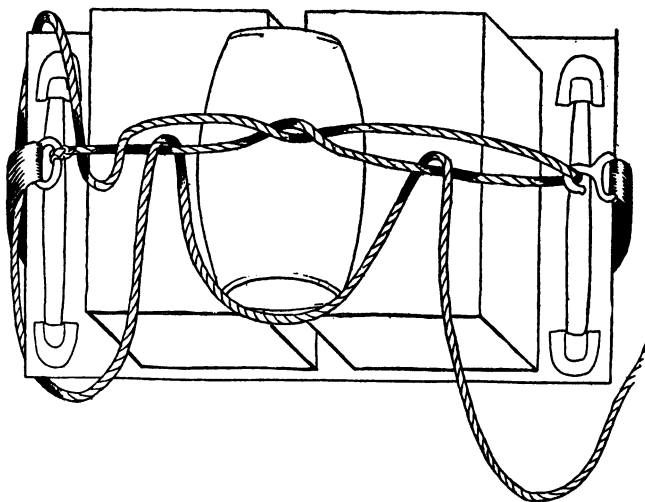

Fig. 6

*Fig. 6.* No. 2 grasps the end of the rope and passes it *under and up* between the two central ropes and prepares to loop it under the off rear corner of the sobre-jalma.

Both No. 1 and No. 2 assist each other at this point in adjusting the rear loop that is to secure the riding load. The point for this rope to bind varies according to the nature of the riding load. It must bind at a place where it will not slip forward, or up or in any direction; with a soft sack there is no difficulty, but with a hard keg or box some precision is needed.

(In the diagrams only the clearness of following the rope has been kept in view and the keg more easily visualizes the riding load.)

The position of the lash rope is now as indicated by *Fig. 6.*

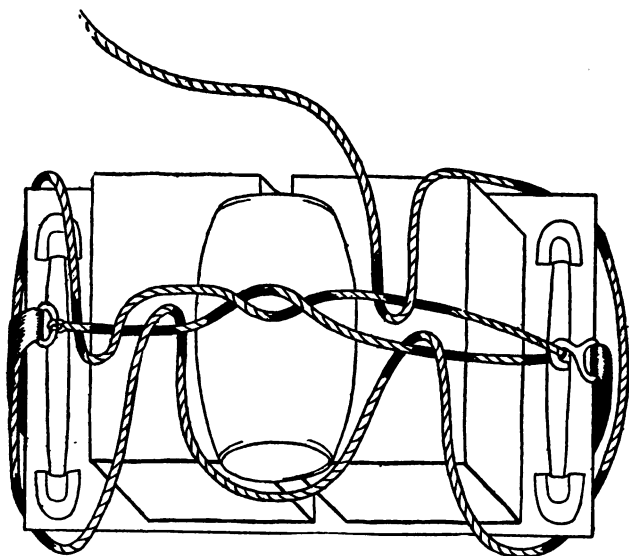

Fig. 7

*Fig. 7.* No. 2 passes the rope under the off near corner of the sobre-jalma, forward and *outside* of the cincha and hook, under the off forward corner of the sobre-jalma and passes it *over and down* through the two central ropes at a point between the riding load and the side load.

He then calls:

"*Take*"

and throws the end of the rope over the mule's neck to *No. 1*.

The lash rope at this point is as indicated in *Fig. 7*.

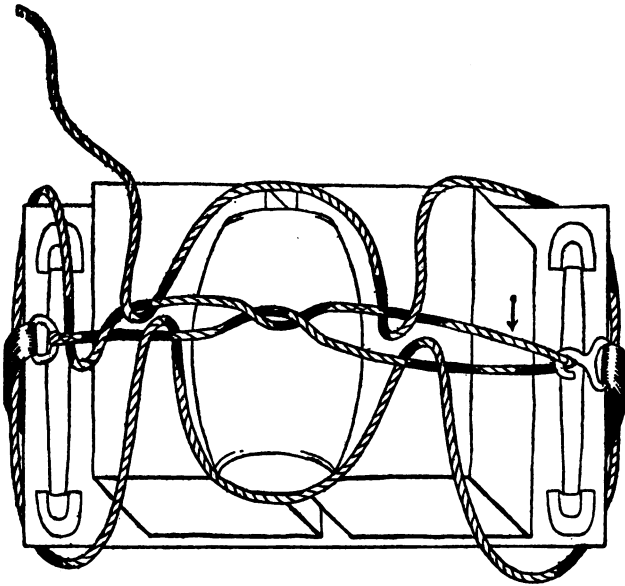

Fig. 8

*Fig. 8.* No. 1 grasps the rope and passes it *under and up* through the two central ropes at a point half-way between the riding load and the side load, and drops the end on the ground. The lash rope must now be tightened.

The lash rope at this point is as indicated in *Fig. 8.*



*Fig. 9. No. 1 commands:*

*"Cinch."*

At this command *No. 2* grasps the running part of the two central ropes (indicated by the arrow, *Fig. 8*), and, by lifting on it, tightens the cincha.

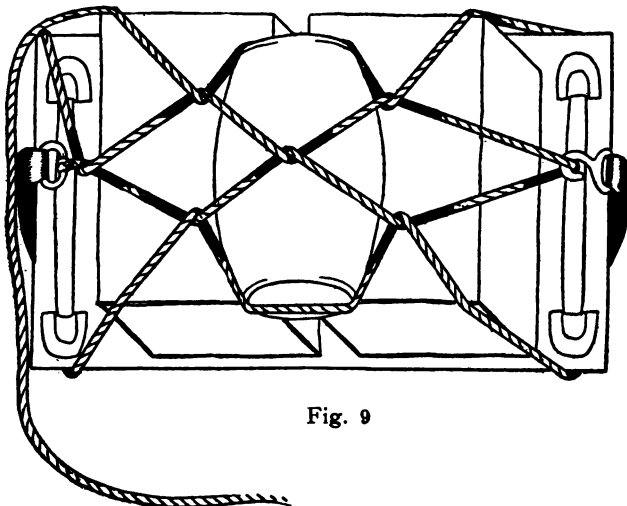

*Fig. 9*

At the same time *No. 1* grasps the same rope on his side and, by throwing his weight down on it, hauls in the slack made by *No. 2*.

*No. 1* holds the slack taken in and follows the lash rope along as in making the original hitch, taking in all the slack he can secure by his strength.

As he reaches the rear loop on the hitch, *No. 2* stands ready at the rear on the off side and takes the slack passed to him without losing the tension. *No. 2* then follows the hitch around in the same manner taking in all the slack possible. As he reaches the forward off side he passes the final slack across the mule's neck to *No. 1*. *No. 1* takes it without losing tension.

The position on the lash rope is now indicated by *Fig. 9*.

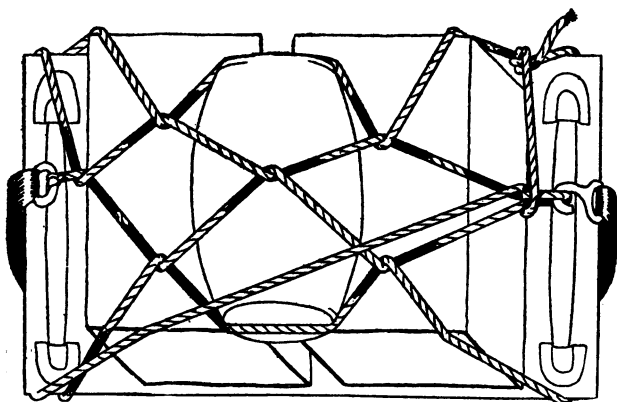

Fig. 10.

*Fig. 10.* No. 1 takes the slack, without losing tension, and passes it under the near forward corner of the sobre-jalma, on to the rear under and *outside* of the cincha, up around the near rear corner of the sobre-jalma and throws it over and across the load calling to No. 2:

*"Take it all."*

No. 2 seizes the rope bringing the end forward of the two central ropes, passing it under and to the rear of them and bringing it forward again in a single turn or half hitch. He passes it around the off forward lashing, throws his weight into it in a final pull and makes it fast. The load is now secured by the Double Diamond Hitch.

The position of the lash rope is now as indicated in *Fig. 10.*

As familiarity with the double diamond is acquired there will be many little short cuts in throwing the rope that will appear. For instance, in *Fig. 7* it is apparent that the quickest way for *No. 2* when he receives the rope at the off-side rear, is to pass it *all* under *both* of the central ropes and letting the end fall somewhere forward; then to pull out from between the two central ropes a bight or loop that can be cast with a rapid motion over both the forward and rear corners of the load and sobre-ialma.

The point aimed at by these diagrams is perfect lucidity and, in explaining, the absolute sequence of the progressive movements. Whatever short cuts there are, are for each individual packer and do not change the order of operations. The commands and responses are merely to time the movements without waste.

### WIMAN ONE-MAN HITCH

The best and simplest of the one-man hitches; it can be thrown by one man without assistance.

(See method of slinging cargo for one man..)

*To avoid confusion in the diagrams the sling ropes are not shown.*

*The load being balanced and slung to throw the Wiman One-Man Hitch:*

**Fig. 1.** Standing on the near side of the mule the *Packer* doubles the lash rope, laying the double rope between the two loads with the loop or *bight* lying to the rear.

The doubled rope is laid between the loads in such a manner that the end or *running part* lies over and on top of the standing part of the lash rope. (*Fig. 1.*)

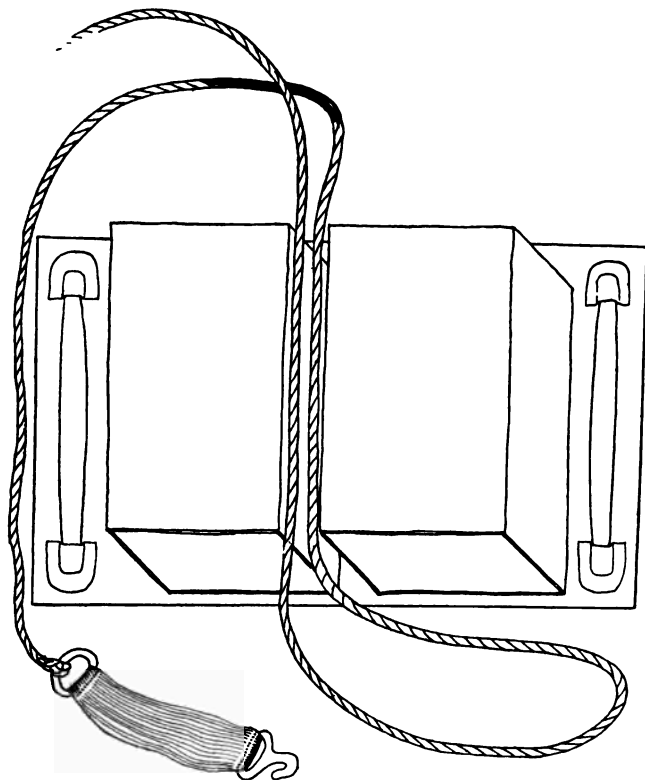

Fig. 1

The doubled rope comes out between the loads and falls on the *near* side of the mule's neck.

The standing part of the lash rope with the cincha trails to the rear on the *near* side, and is grasped by the packer

The position of the lash rope is now as indicated in *Fig. 1.*

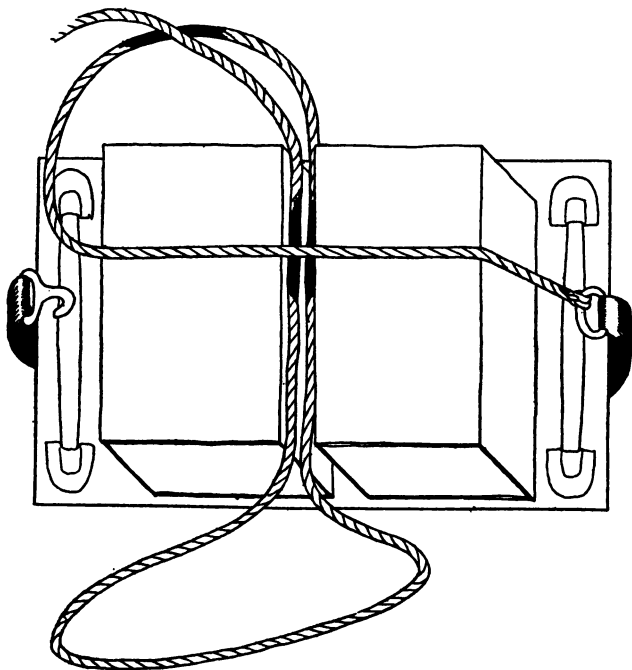

Fig. 2

**Fig. 2.** The *Packer* throws the cincha across the load and, reaching under the mule's belly, catches the cincha hook and brings it up on the near side. The position of the lash rope is now as indicated in *Fig. 2*.

**Fig. 3.** The *Packer* engages the lash rope in a half-hitch on the cincha hook, keeping the lash rope fairly taut on the cargo.

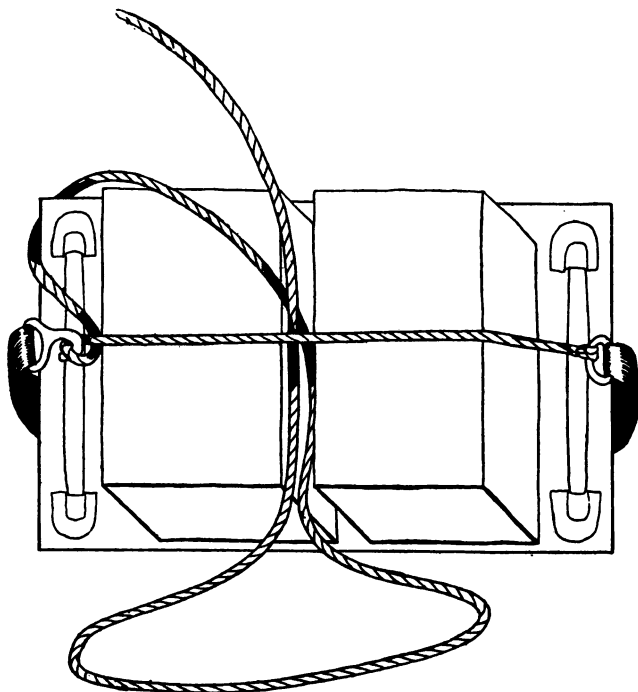

Fig. 3

The free end of the half-hitch *must* be on the inside, i. e., between the standing part of the lash rope and the mule, or sobre-jalma (see *Fig. 3*).

He then carries the bight of the lash rope forward and loops it over the forward near corner of the sobre-jalma and on up over the forward near corner of the near load.

The position of the lash rope is now as indicated in *Fig. 3*.

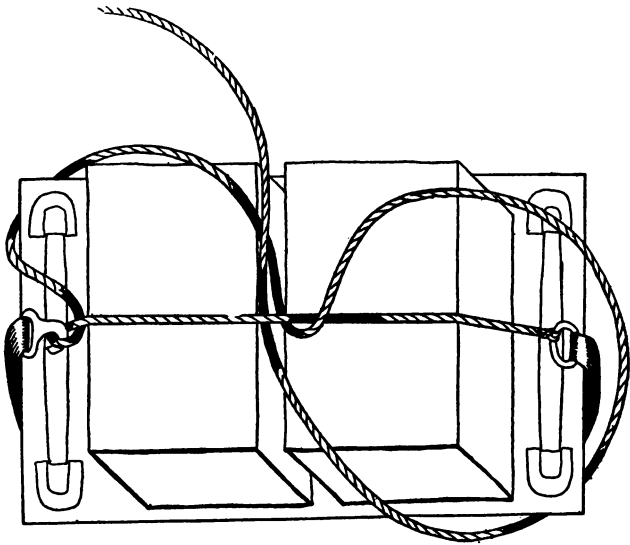

Fig. 4

**Fig. 4.** The Packer now passes along the near side to the rear of the mule where he takes up the bight of the lash rope that comes out between the two loads.

The right half of the bight he prepares to carry forward on the off side at the same time dropping the left of the bight under the rear off corner of the sobre-jalma.

The position of the lash rope is now indicated in Fig. 4.



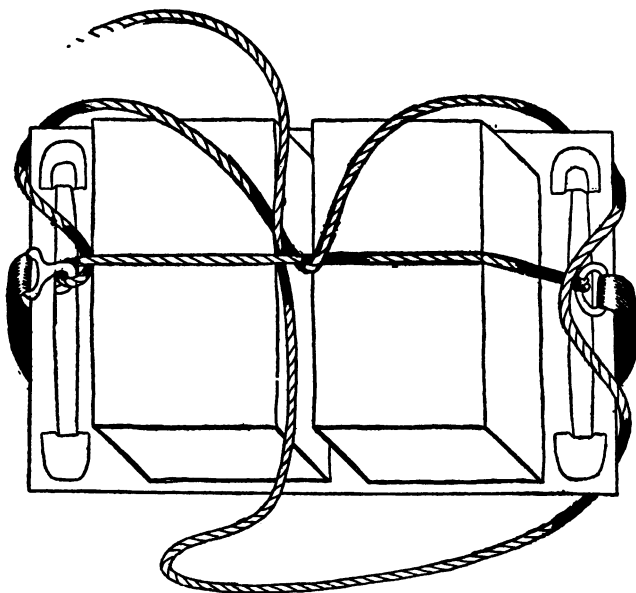

Fig. 5

**Fig. 5.** The Packer loops the right half of the bight over the side load and down under the forward off corner of the sobre-jalma, drawing it moderately taut.

He then passes to the rear along the off side adjusting the bight along the *outside* of the cincha and keeping it taut under the off rear corner of the sobre-jalma.

The position of the lash rope is now as indicated in **Fig. 5.**

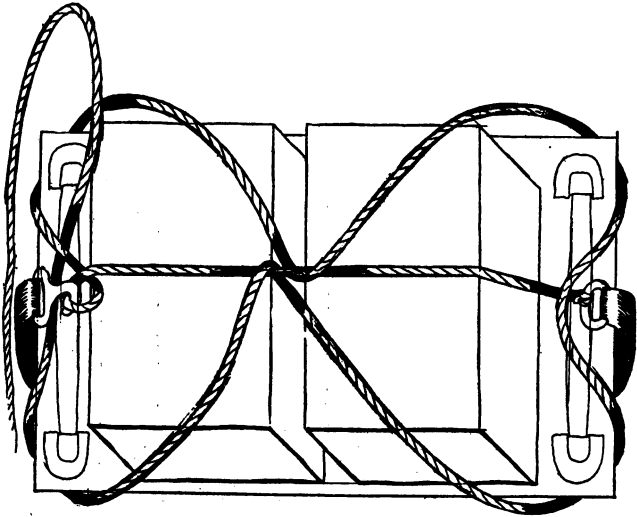

Fig. 6

**Fig. 6.** The Packer now passes in rear of the mule and takes the free end of the lash rope, bringing it to the rear and *over* the standing part that lies across the cargo from the cincha ring to hook. He brings this free end over and down, passing it under the rear near corner of the sobre-jalma. Then he brings the end forward on the rear side and *under* the cincha hook, letting the free end fall forward. It is now time to cinch the cargo. The position of the lash rope is now as indicated in *Fig. 6.*

**Fig. 7.** To cinch the cargo the Packer begins with the lash rope that crosses the load from the ring to the hook. He sees that this lies straight across the centre of the cargo. Then he grasps the lash rope *after* it has passed around the hook and tightens it with all his strength.

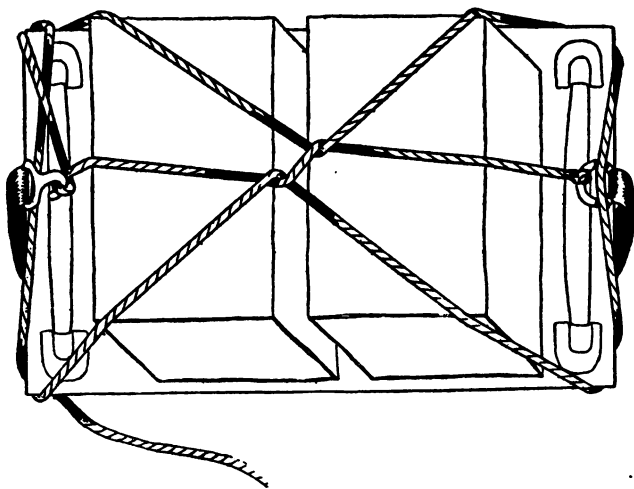

Fig. 7

Holding it taut he proceeds to work along the lash rope in the same order in which he first threw the hitch, heaving with all his strength and holding taut the slack so taken.

When he has again reached the free end the Packer brings it over and down under the forward corner of the *sobre-jalma* and passes it, still keeping it taut, to the rear *outside* of the *cincha* or hook.

The position of the lash rope, cinched, is now as indicated in *Fig. 7*.

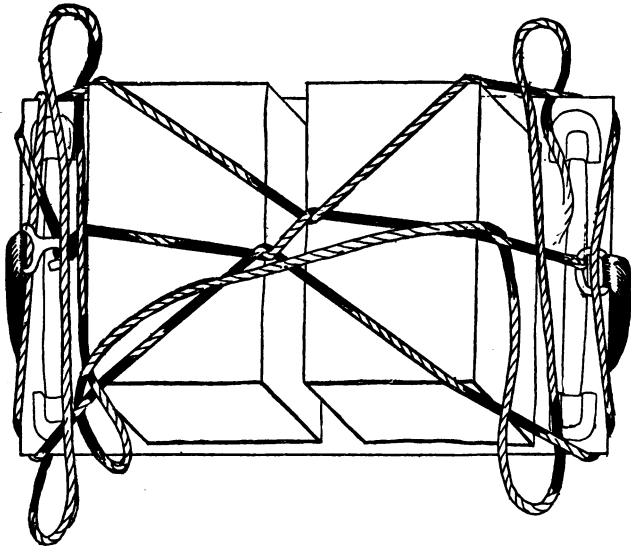

Fig. 8

**Fig. 8.** These are in reality frapping turns. They are lacings that bind the hitch with great rigidity on each side.

The Packer brings the free end of the rope up and forward *over* all of the ropes. The rope is passed *over* the near forward part that binds on the load, and then back to the rear part that binds on the load where a half turn is taken that leads up and *over* the load (see detail in *Fig. 8*).

The packer now goes to the farther side of the mule where the free end of the lash rope is passed under the central part, thence to the rear and around the part that binds on the load. Then forward on the off side and passed around the part that binds the load there.

The position of the lash rope is now indicated in *Fig. 8*.

*Fig. 9.* The lacings just described are now cinched. (While they are being made they should be kept fairly taut.)

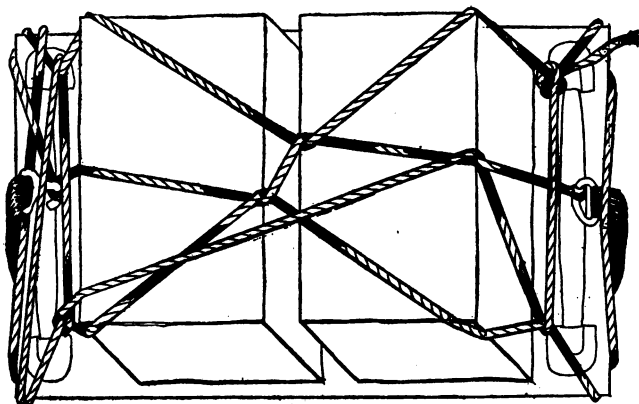

*Fig. 9*

They are cinched by going over them, hauling each taut in turn and finally securing by any kind of knot the packer may fancy.

The position of the lash rope is now as indicated in *Fig. 9*.

The kind of knot used to secure a hitch is a matter of individual preference, though it also depends on the character of the lash rope used. A single bow-knot, or a reef slip-knot as it is sometimes called, is best when it can be used, for ease of casting off is a necessary factor. A rawhide lash rope is very perverse. If a rope can be jammed in one of its own bearings the result is most convenient—or rather a combination of simple knot and then a jam.

It must be borne in mind that to preserve the clearness of the diagrams many factors have been sacrificed. The ropes that bear directly on the load and that radiate from the common center (see *Fig. 7*) should always pass over the front and rear of the side loads at approximately the center of pack. This is true of all hitches.

### **POLE HITCH**

A one or two-man hitch.

The *Pole Hitch* lashes the two side packs to each other with great strength, but at the same time does not compress the loads on the pack mule. It will be noted that no cincha is used and that the lash rope does *not* pass under the belly of the animal. It is used for lashing on the poles of a travois or of a litter.

It is a very simple hitch, being nothing but a half-hitch taken on each side and around the pack, and then laced for additional strain.

One packer can throw it if necessary.

*To avoid confusion in the diagrams the sling ropes are not shown.*  
*Fig. 2.*

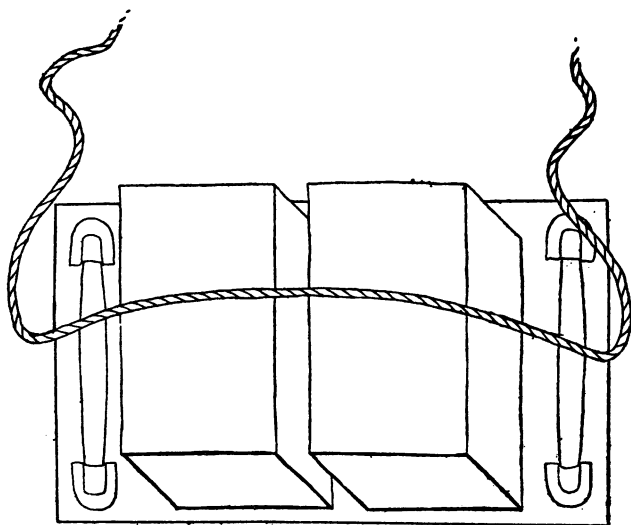

Fig. 1

*The packs being slung to throw the Pole Hitch:*

*Fig. 1.* No. 1 throws the lash rope (without the cincha, it having been removed first) across the pack so that the middle of the rope rests in the centre of the packs. He commands

*"Take."*

The position of the lash rope is now as shown in Fig. 1.

No. 2 seizes his half of the rope.

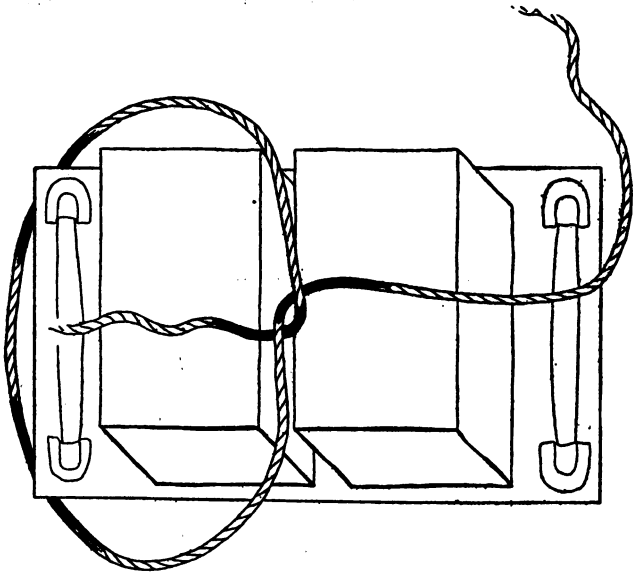

Fig. 2

(Note.—Both *No. 1* and *No. 2*, in actual practice throw the hitch simultaneously as the movements for the hitch on the near and off sides of the mule are identical. But for simplicity of description and diagrams it will be explained as though consecutive operations—or as though it was being thrown by but one man acting as *No. 1* and also a *No. 2* acting at the same time.

**Fig. 2.**

*No. 1* now passes his rope to the right, around the upper right hand corner of the pack, on around under the *sobre-jalma* and up and around the upper left hand corner of the pack.

He passes the end of the rope over and down under the standing part.

The position of the lash rope is now as shown in *Fig. 2*.



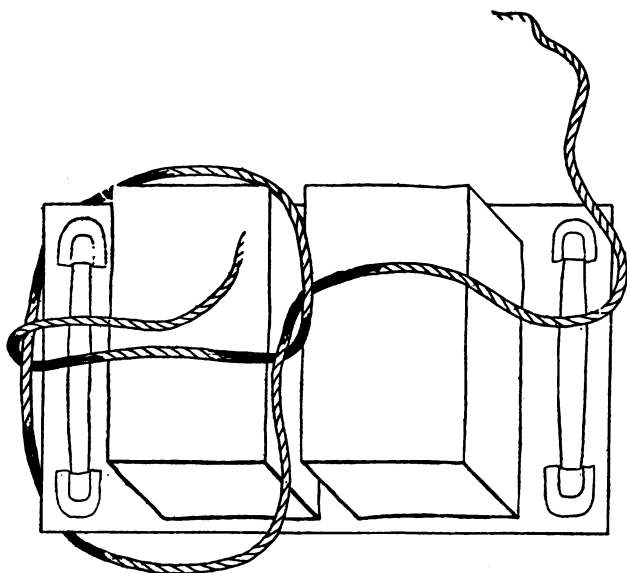

Fig. 3

**Fig. 3.** No. 1 now lifts the bight of the lash rope from below the center of the sobre-jalma and passes the end of the rope down under and through the bight, bringing the end up and outside the bight. The position of the lash rope is now as shown in Fig. 3.

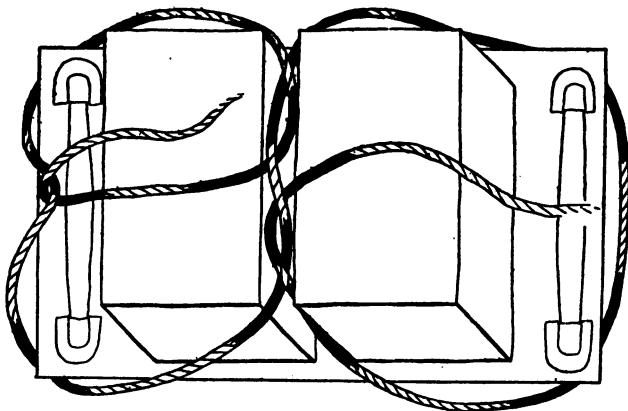

Fig. 4

**Fig. 4.** *No. 2*, when the rope was thrown to him (as in *Fig. 1*) performs on his side exactly the same operations as have been just described for *No. 1* and prepares to pass the end of the rope under and through the bight below the *sobre-jalma*. It will be observed that here are two half-hitches, one on either side of the pack mule. The position of the lash rope is now as indicated in *Fig. 4*.

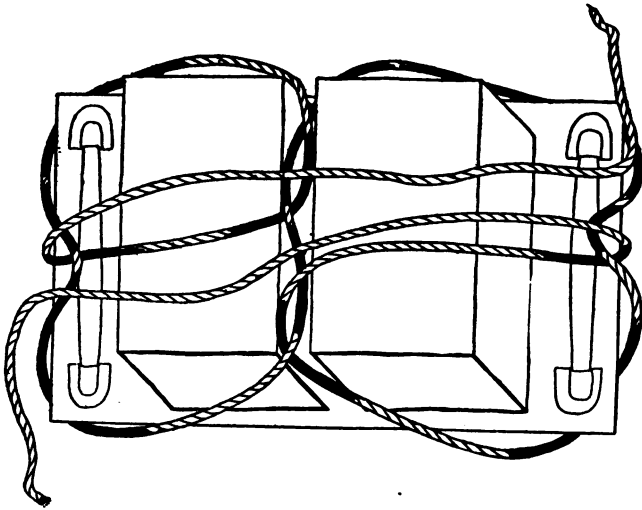

Fig. 5.

*Fig. 5.* *No. 1* now throws the end of his rope across the packs at the same time calling:  
"Take."

*No. 2* at the same time throws *his* end of the rope across to *No. 1* calling:  
"Take."

The position of the lash rope is now as shown in *Fig. 5.*

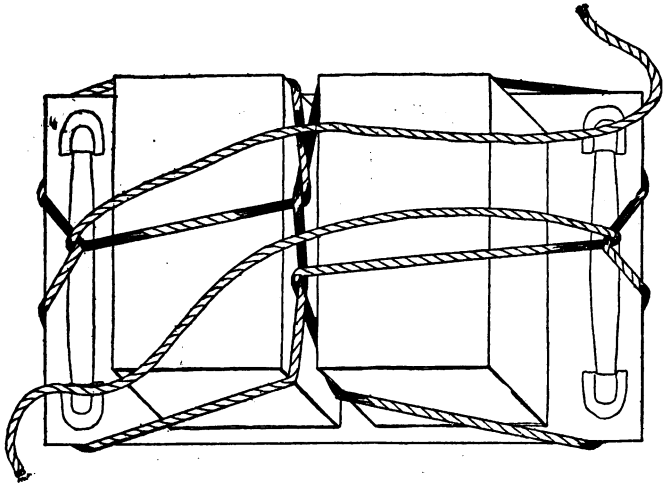

Fig. 6.

**Fig. 6.** The hitch is now ready to tighten.

*No. 1* holding the end of the rope thrown him so as to take and keep any slack, commands:  
"Cinch."

At this *No. 2* takes up the slack on his side going over the hitch from the beginning and taking up the slack. *No. 1* takes and holds such slack.

*No. 2* calls:

"Tie."

*No. 1* makes his rope fast.

*No. 2* then holds the rope passed to him in such a way as to take up and hold all slack gathered.

*No. 1* proceeds to take up slack as did *No. 2*.

As the last slack is taken he calls:

"Tie."

and *No. 2* makes his rope fast.

The position of the lash rope is shown in *Fig. 6* as having been cinched but not tied.

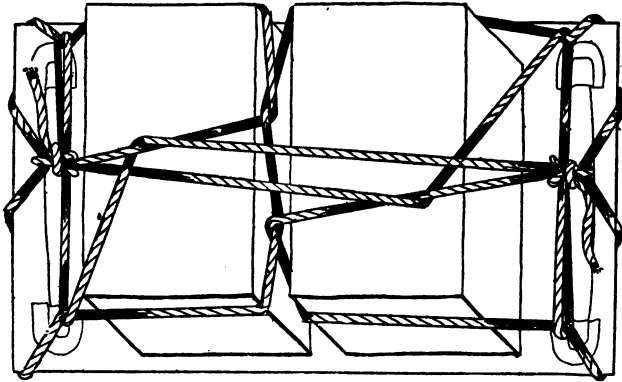
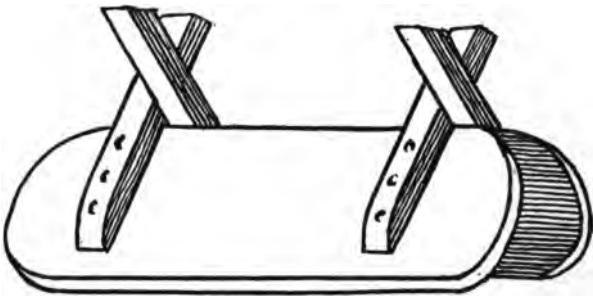

Fig. 7.

**Fig. 7.** In Fig. 7 the *Pole Hitch* is shown complete. The lacings on the side bring a great compressing strain. While this diagram does, of necessity, appear to illustrate a somewhat complicated hitch, yet the Pole Hitch is one of the simplest and most easily tied. The Pole Hitch is used for lashing the poles of a Travois to the animal; this is its use.



Sawbuck Saddle

The *Saw Buck Saddle* is a wooden frame as shown in the above illustration, made of some hard, tough wood. It is placed above the ordinary saddle blankets and held in place by the latigo cinch on girth as shown in second illustration below. It is a small frame no larger than is necessary to give firm support to the cross pieces at each end.

With the Saw Buck it is easier for one man to sling the cargo.

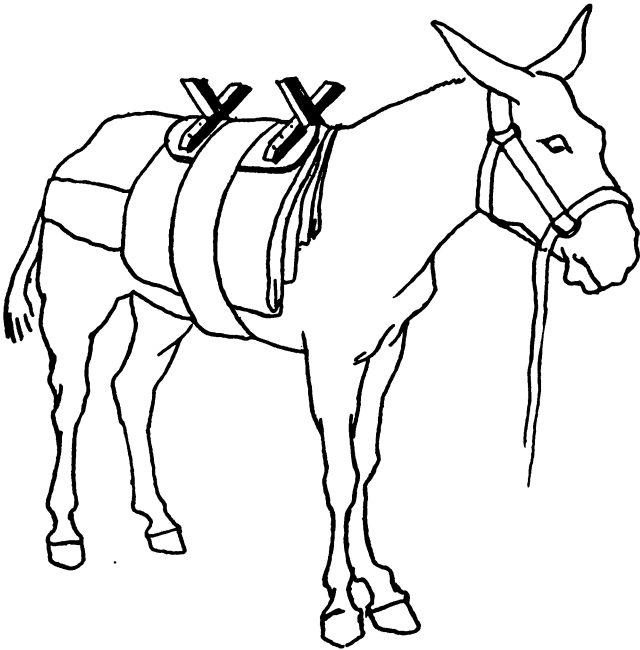

Sawbuck Saddle—In place

The only function it performs is to aid in slinging the cargo. It is always the *hitch* that holds the cargo firmly to the mule. The sling merely holds it in position while the hitch is thrown.

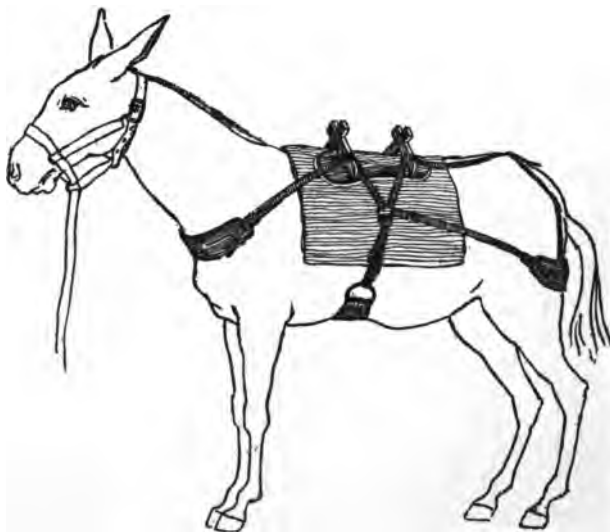

**Sawbuck Saddle**

**A saw buck saddle and gear for army or trail use.**



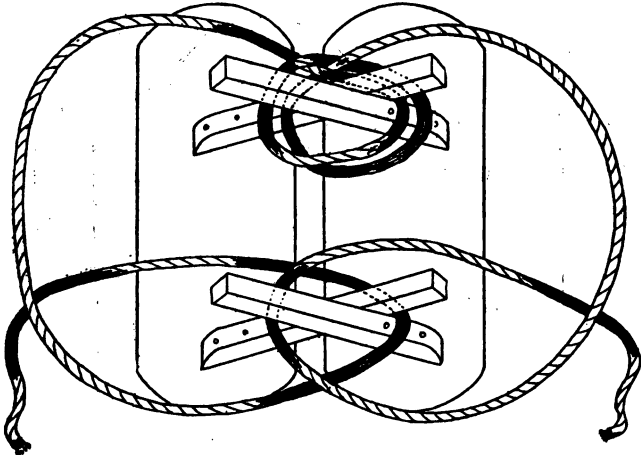

Fig. 1

### SAW BUCK SLING

*The mule being equipped with the Saw Buck to sling the load:*

*Fig. 1.* The Packer makes a clove hitch at the centre of the sling rope and slips it over the forward forks of the saw buck. He throws that portion of the sling rope that comes naturally out at the farther side over to the off side, allowing that end of the sling rope that comes naturally out on the near side to remain there.

He then takes the rope that is on the near side and loops it over the off crotch of the rear saw buck from rear forward. He allows the end to drop down underneath the bight thus formed along the saddle.

This bight is to receive the side pack and should be of sufficient size.

The packer then makes a similar bight in a similar way on the off side.

The position of the sling rope is now as shown in *Fig. 1.*

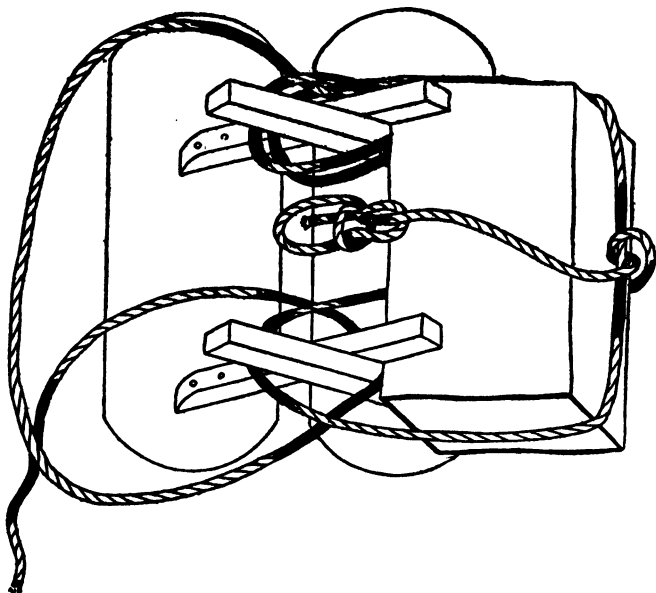

Fig. 2

**Fig. 2.** Being now on the off side the packer picks up the off pack and lifts it into the off bight, and brings the load as high toward the saw buck as possible. He takes up the slack of the bight so that the rope holds the pack in position as tightly as possible. The packer now brings up the end of the rope from under the off pack, taking one full turn around the bight that holds the pack in position. This turn is taken at the centre of the bight. He now makes a bowline in the end of the off sling rope in such a way, or place, that when cinched it will come about in the centre of the load between the packs. The position of the sling rope is now as shown in **Fig. 2.**

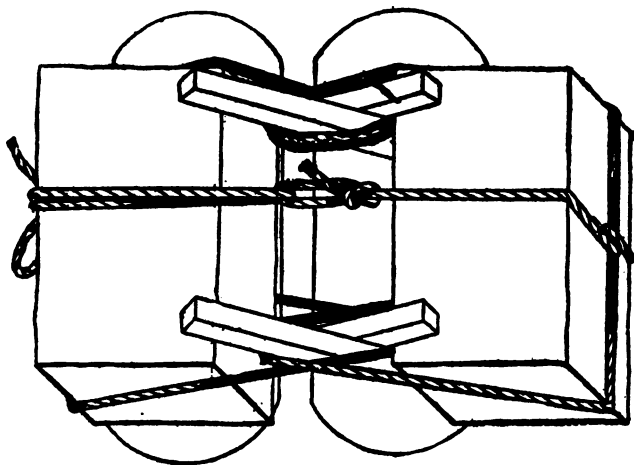

Fig. 3

**Fig. 3.** The packer now passes to the near side where he slings the near side pack in the same manner as just prescribed for the off side pack. In this case he does not make a bowline. He passes the end of the near sling rope (after a full turn around the near bight at the centre of the sling) through the bight of the bowline on top of the load and heaves hard. He then makes fast and the load is slung ready for the hitch. The position of the sling rope is now as shown in Fig. 3.

## NO. 2 SAW BUCK SLING

This is another method of slinging on a saw buck saddle and is adapted, as the diagrams show, to such loads as are longer and more awkward.

*The mule being equipped with the saw buck saddle to sling the load.*

*Fig. 1.* The *Packer* makes a clove hitch at the centre of the sling rope and slips it over the forward forks of the saw buck allowing the one end to drop

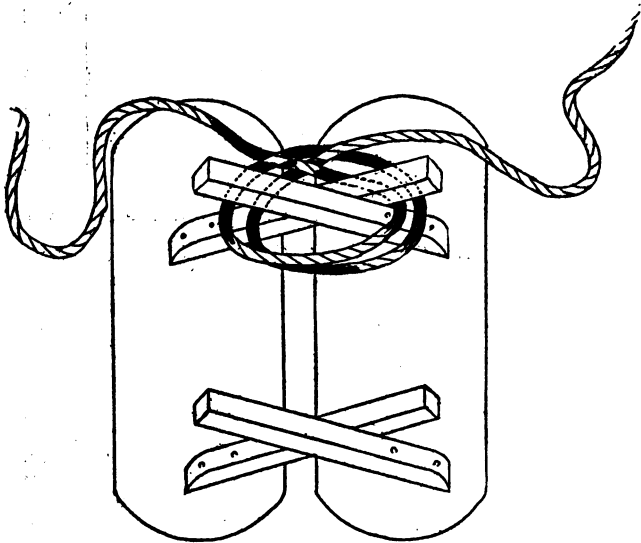

Fig. 1

naturally down on the near side and the other he throws across the mule's neck to the far side. The position of the sling rope is now as shown in *Fig. 1.*

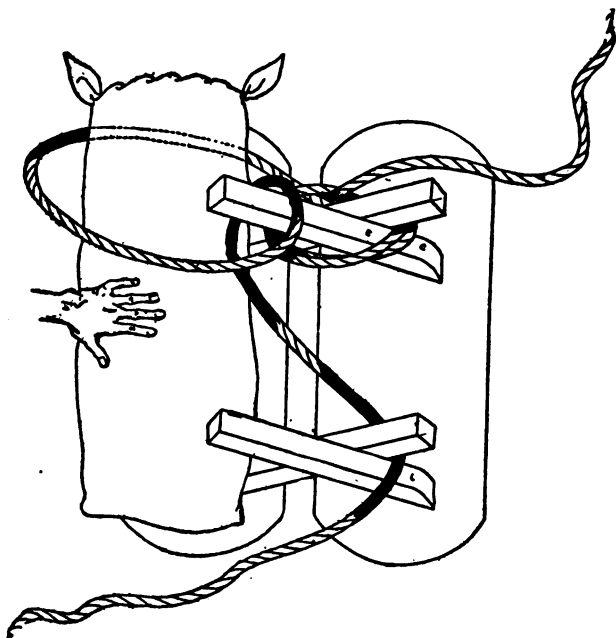

Fig. 2

**Fig. 2.** The packer lifts the near load as high up into position as possible and holds it into place (with his shoulder) while he slips the near rope in a loop around the forward end of the pack. He then takes a half-hitch around the near arm of the fork. He then passes the sling rope on over the rear of the saw buck and throws it into the off crotch. The position of the lash rope is now as indicated in Fig. 2.

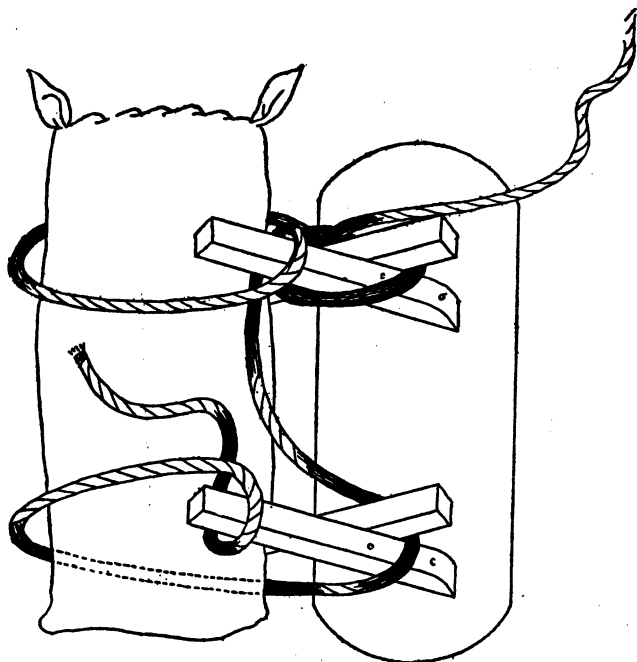

Fig. 3

*Fig. 3.* The packer now forms a loop with the end of the sling rope that falls from the crotch of the rear fork and places the rear end of the pack in the loop so formed. He then brings up the end, takes a turn around the near rear fork and makes fast after bringing the pack as high on the saddle as possible. The position of the sling rope is now as shown in *Fig. 3.*

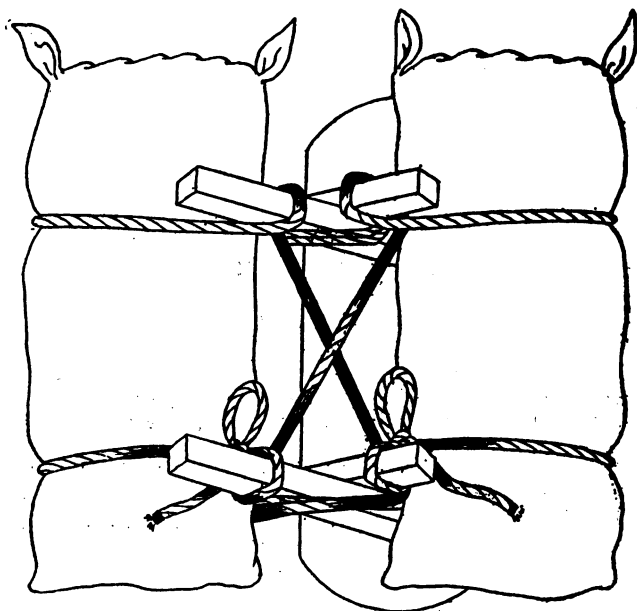

Fig. 4.

*Fig. 4.* The packer now passes around to the off side and slings the off pack in exactly the same manner as he slung the near pack. The position of the sling rope is now as shown in *Fig. 4.*

**CROSS-TREE HITCH*****A One-Man Hitch***

This is a single-diamond and is generally used on the saw buck saddle. It is one of the few hitches that can be thrown as easily by one man as by two.

*To avoid confusion in the diagrams the sling ropes are not shown.*

This hitch is shown as thrown using the sobre-jalma. A sobre-jalma is not essential where the Saw Buck is used, but it adds to the convenience.



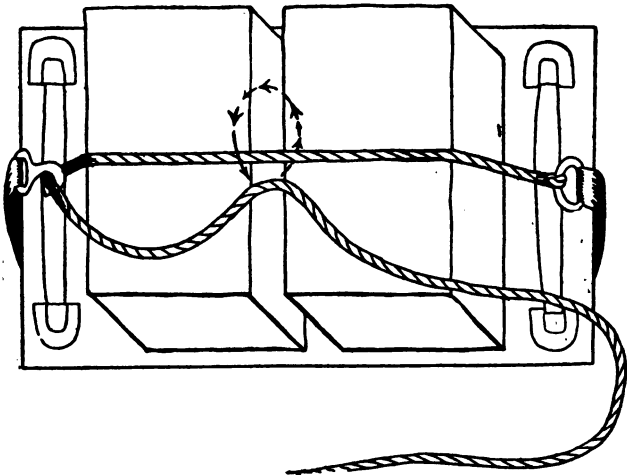

Fig. 1

*The packs being slung to throw the Cross-Tree Hitch:*

*Fig. 1.* The *Packer* throws the cincha and lash rope across the packs bringing the hook end of the cincha up under the belly of the mule and on the near side.

He engages the lash rope under the hook, draws up the slack and throws a fair sized bight of the rope across the packs.

The position of the lash rope is now as shown in *Fig. 1.*

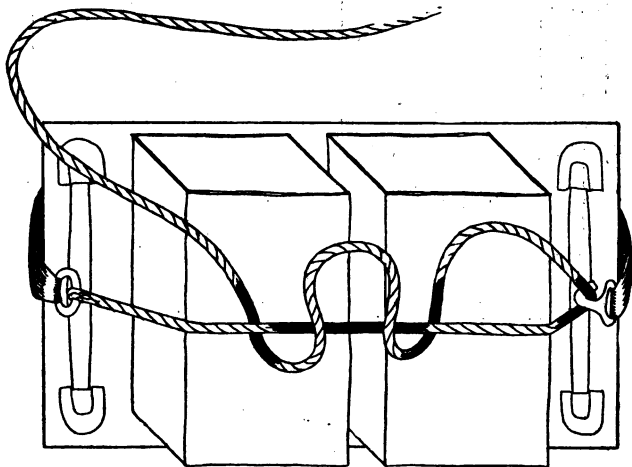

Fig. 2

**Fig. 2.** The packer now passes this bight *under* and *forward* of the standing rope, bringing it back over the standing rope (as indicated by the arrows in *Fig. 1*) preparing to make one complete turn around the standing rope with the bight. The position of the lash rope is now as shown in *Fig. 2*.

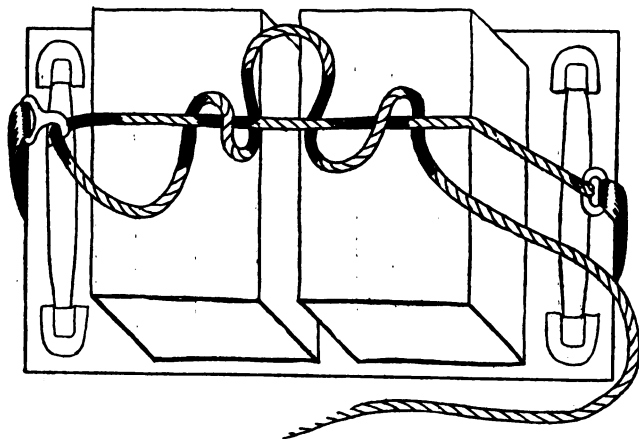

Fig. 3.

**Fig. 3.** The packer now passes the bight once again *under* and forward of the standing rope, thereby completing *one full turn* of the bight around the standing rope. The size of the bight forward of the standing rope varies and depends upon the shape and size of the load. The position of the lash rope is now as shown in **Fig. 3.**

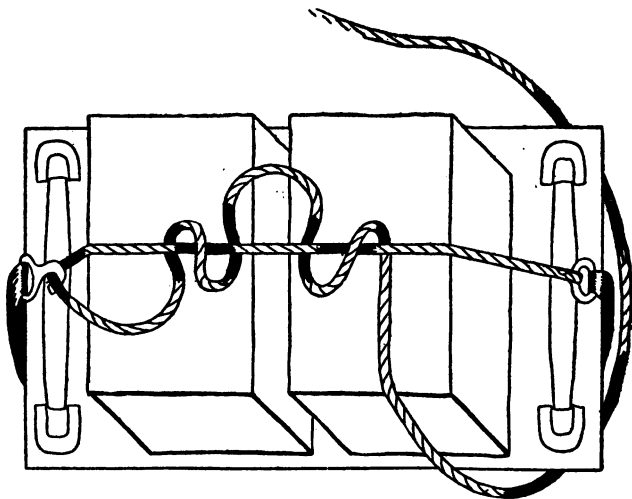
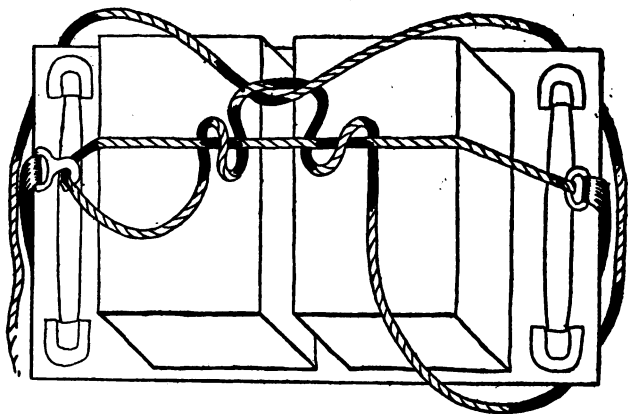

Fig. 4.

**Fig. 4.** The packer now throws the free portion of the lash rope over the mule in rear of the packs. He passes around to the off side bringing the rope now on the off side over and down around the rear upper corner of the off load then down and under the sobre-jalma. The position of the lash rope is now as shown in **Fig. 4.**



**Fig. 5.** The packer now passes the rope forward and under the corner of the sobre-jalma but outside the cincha, up and around the upper forward corner of the off pack and thence *through the bight* lying on top of the packs.

He then throws the rope across the mule's neck over to the near side.

He now passes to the near side and brings the rope down over the forward corner of the near pack and under the corner of the sobre-jalma.

The position of the rope is now as shown in **Fig. 5.**

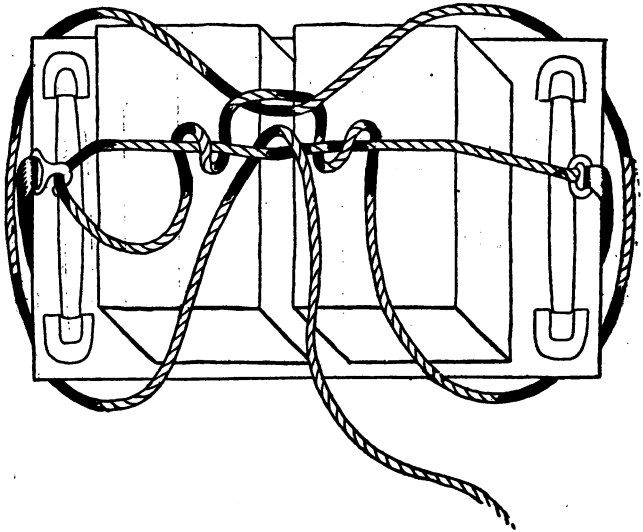

Fig. 6.

**Fig. 6.** The packer now brings the rope to the rear *under* the sobre-jalma, but outside of the cincha, then up over the near corner of the near pack and through that portion of the standing rope enclosed within the bight. The hitch is now ready to cinch and tie. The position of the lash rope is now as shown in *Fig. 6*;

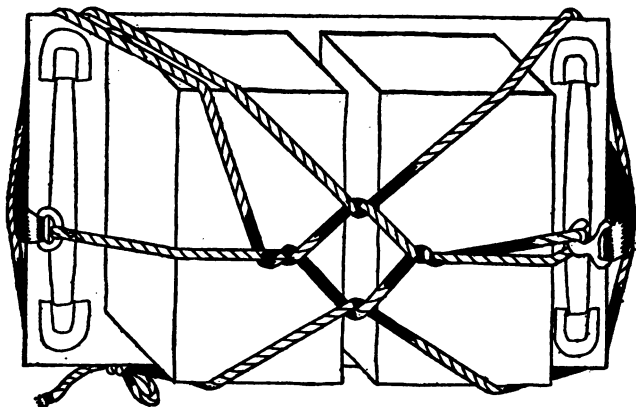

Fig. 7.

*Fig. 7.* The packer now cinches the hitch in the usual manner, following the slack in the original turns and taking it in.

When it has been taken (up to the point shown in *Fig. 6*) he passes with the rope to the off side in rear of the mule, bringing the rope once more down around the rear of the off pack and forward under the sobre-jalma and outside the cincha, and makes fast as usual.

The position of the lash rope is now as shown in *Fig. 7.*

### THE SQUAW HITCH

*(Also known as the Cross-Tree Hitch)*

This is one of the earliest of "one-man hitches" and has been used by the American Indians for centuries. As the squaws do the packing the early frontiersmen gave it the name "squaw hitch." It is a very simple hitch and in very general use in small one-man prospecting outfits. It is not to be compared with any of the diamond hitches. The Wiman one-man hitch is much more scientific in its adjustment and is invariably to be preferred.

*To avoid confusion in the diagrams the sling ropes are not shown.*

*The load being balanced and slung to throw the squaw hitch:*

*Fig. 1.* The packer throws the cincha across the cargo and reaching under the mule's belly catches the hook end of the cincha bringing it through and up into position on the near side.

He then engages the lash rope that falls from the cargo in such a manner that the free end of the lash rope leaves the hook on the outside (See *Fig. 1*). He adjust the cincha and throws a light strain on the rope to hold it in position.

With the free or running portion of the lash rope



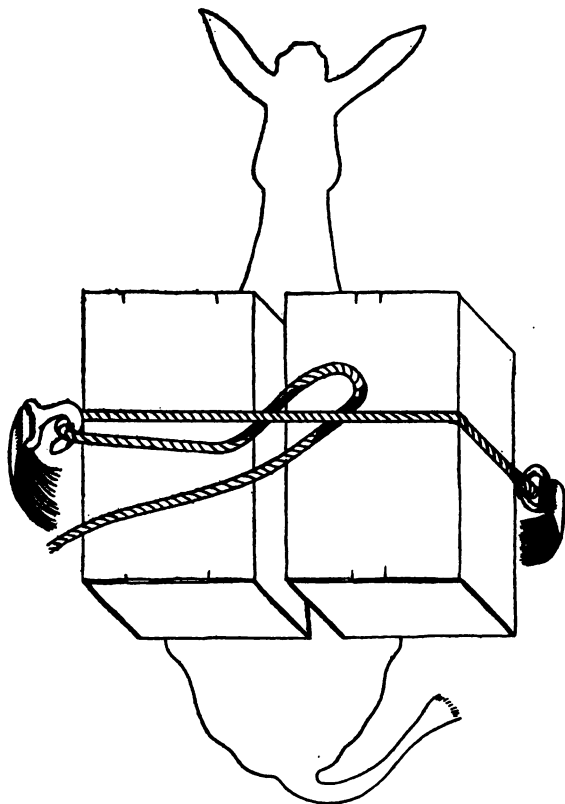

Fig. 1

he forms a bight *to the rear* of the taut standing part, and then passes the bight *under and forward* of the standing part in the center between the two side loads.

The position of the lash rope is now as indicated in *Fig. 1*.

**Fig. 2.** The packer then pulls the free end of the bight all the way through the standing part.

Holding taut the free or running part of the lash rope he passes to the rear of the mule over to the off side. He brings the rope down over the rear corner of the off side of the load and carries it forward underneath the rear corner of the load. (And under, also the rear corner of the sobre-jalma if there is one used.)

He then carries the lash rope forward *outside* of the cincha or standing part of the rope and loops it around the off forward corner of the load and then on over the center of the cargo *over* the standing part of the lash rope and *under* the part of the rope that forms the off rear loop. (See *Fig. 2.*)

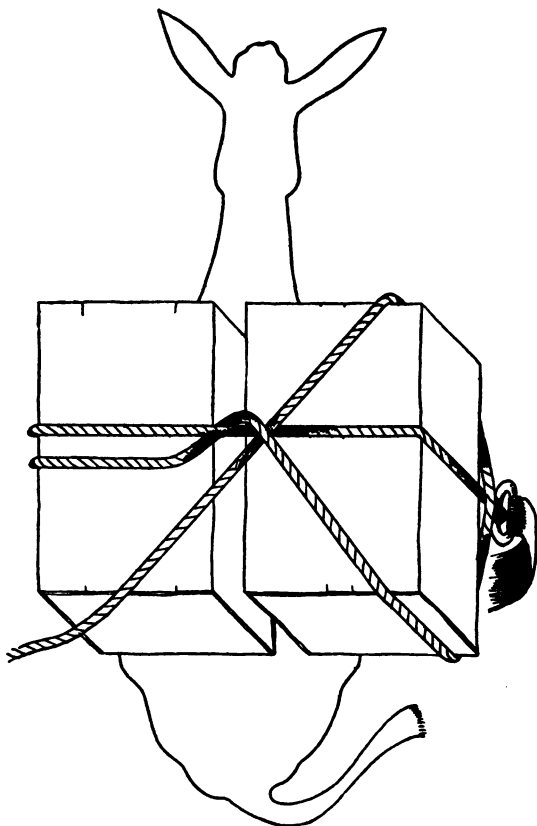

Fig. 2.

Keeping the rope moderately taut the packer now passes from the off side of the mule, around by the rear to the near side. The position of the sling rope is now as shown in Fig. 2.

**Fig. 3.** The packer now goes to the near forward corner of the load passing the free portion of the lash rope over the ropes and cargo and then down over the near forward corner of the load. This brings the strain on top of the center of the cargo by engaging the lash rope with the angle of the loop that lashes the off side load in place. (See *Fig. 3.*)

In the same manner as on the off side, he brings the lash rope down and outside of ropes and cincha passing to the rear where he loops the lash rope up and around the near rear corner of the load.

The packer then passes the free end of the lash rope *over* all parts and down into the angle formed by the two forward lashings. Passing the end *down* into this he brings it out and up (passing underneath *all* ropes as he does so) through the angle formed by the two rear lashings.

The hitch is now ready to cinch.

The position of the lash rope is now as indicated in *Fig. 3.*

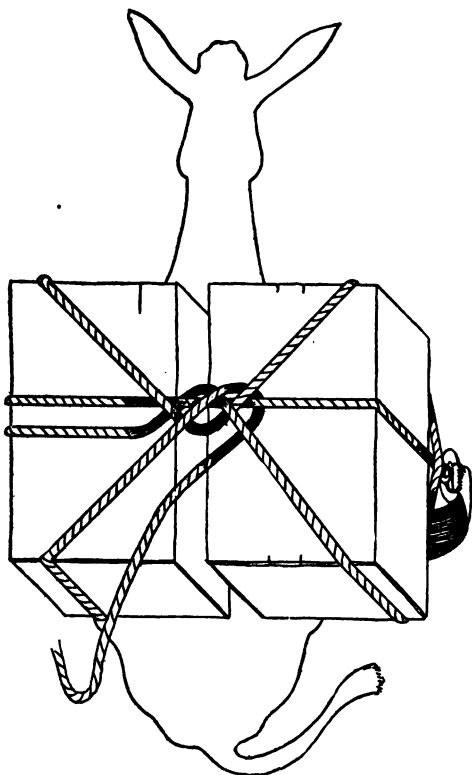

Fig. 3.

*To Fasten:* Bring the free end of the lash rope down in rear of the load on the near side (see *Fig. 3*) and passing it under make fast, preferably around the two parts of the lash rope that lead to the cincha hook.

**LIFTING HITCH*****A One-Man Hitch***

This is a hitch that is used with a saw buck saddle and where no sobre-jalma is used. It has a tendency to lift the corners of the load away from the side of the animal. It is one of the true one-man hitches as one man can throw it as easily as two.

*To avoid confusion in the diagrams the sling ropes are not shown.*

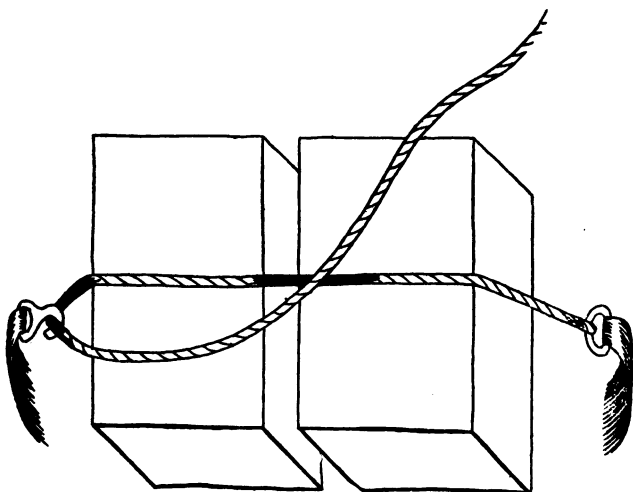

Fig. 1.

*The loads being slung to throw the Lifting Hitch:*

**Fig. 1.** From the near side the *Packer* throws the cincha and rope across the packs. Reaching under the mule's belly he grasps the cincha and brings it out on the near side.

He then engages the rope in the hook and then throws the end of the rope across the packs and forward to the off side

The position of the lash rope is now as shown in *Fig. 1.*

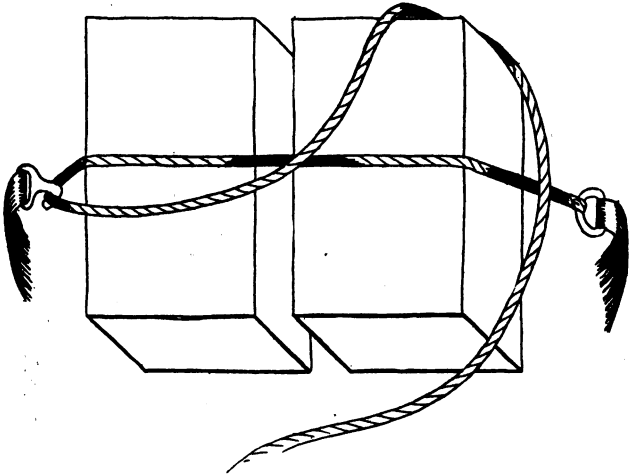

Fig. 2.

*Fig. 2.* The packer now passes to the off side and forward of the load. He passes the lash rope around and over the forward end of the off pack. Then down and to the rear along the lower side of the pack, *outside* the standing part of the lash rope and up around the rear corner of the off pack. The position of the lash rope is now as shown in *Fig. 2.*



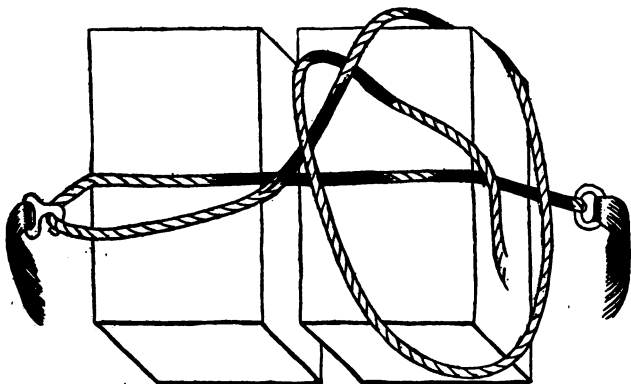

Fig. 3.

*Fig. 3.* The packer now passes the rope up and over and forward along the off pack, over the portions of the lash rope lying there, and then down and under that portion of the rope that passes around the forward part of the off pack. This is in such a manner that the strain when cinched will come between the standing rope and the forward part of the off pack.

The position of the lash rope is now as shown in *Fig. 3.*

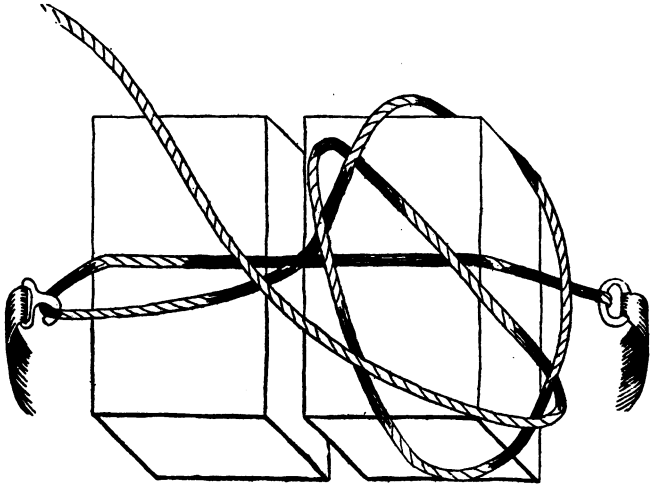

Fig. 4.

*Fig. 4.* The packer now passes the end of the rope on down, *over* the standing rope and *under* that portion of the lash rope that passes along the lower side of the off pack, and brings the end of the rope up and over all ropes. He then throws the rope across the mule and forward so that it falls forward of the near pack. The position of the lash rope is now as shown in *Fig. 4.*

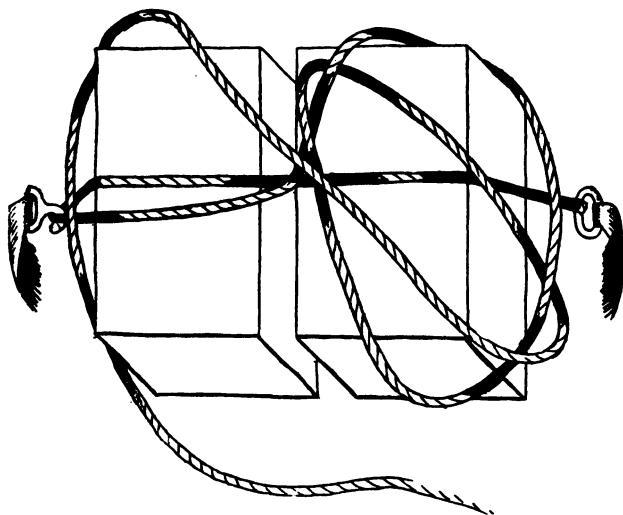

Fig. 5.

**Fig. 5.** The packer now passes around to the near side and passes the lash rope in the same manner as he did on the off side. He brings the rope down over the forward end of the near pack, then down along the lower side of the near pack to the rear. It passes over and outside the standing rope. The position of the lash rope is now as shown in *Fig. 5*.

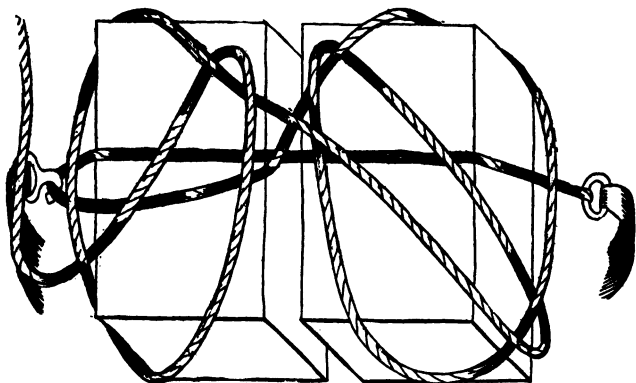

Fig. 6.

*Fig. 6.* The packer now continues in same manner as on the off side. He brings the rope up and around the rear of the near pack, passing forward over all ropes, and then down and under the rope that passes over the forward end of the near pack. Thence down and over the ropes from the hook and *under* the rope that passes along the lower side of the near pack and out and up. The hitch is now ready to cinch. The position of the lash rope is now as shown in *Fig. 6.*

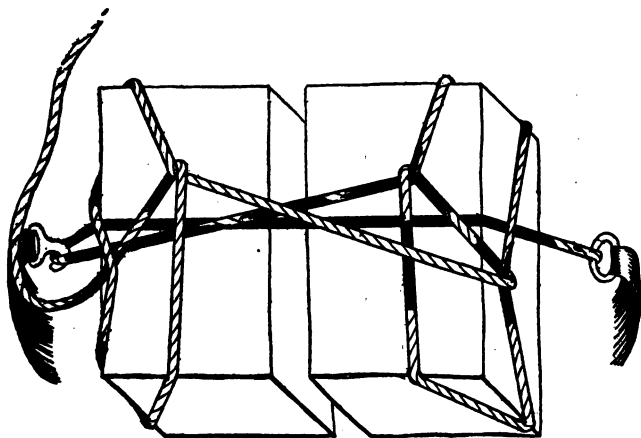

Fig. 7.

*Fig. 7.* The packer now heaves on the ropes in the same manner as when they were first passed, and adjusting each bearing and strain so that it comes relatively on the packs as shown in *Fig. 7*. This varies somewhat with the shape and necessities of the load.

The position of the lash rope is now as shown in *Fig. 7*.

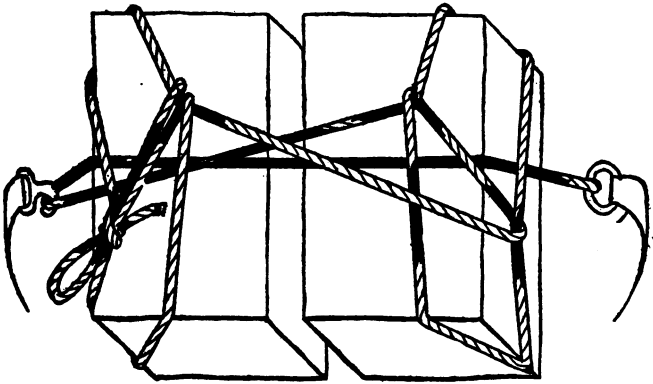

Fig. 8.

*Fig. 8.* The packer now brings up the free end passing it forward and around the rope there, straining it back and making fast  
The position of the lash rope is now as shown in *Fig. 8.*

**STIRRUP HITCH***A Two-Man Hitch*

This is in the order of emergency hitches that may be used with a saw buck saddle, an aparejo, an ordinary riding saddle, or even, in extreme emergency, with nothing more than an animal and a piece of rope if the character of the load permits. It is a two-man hitch, although it can be thrown by one man alone. The lash rope has neither cincha nor hook.

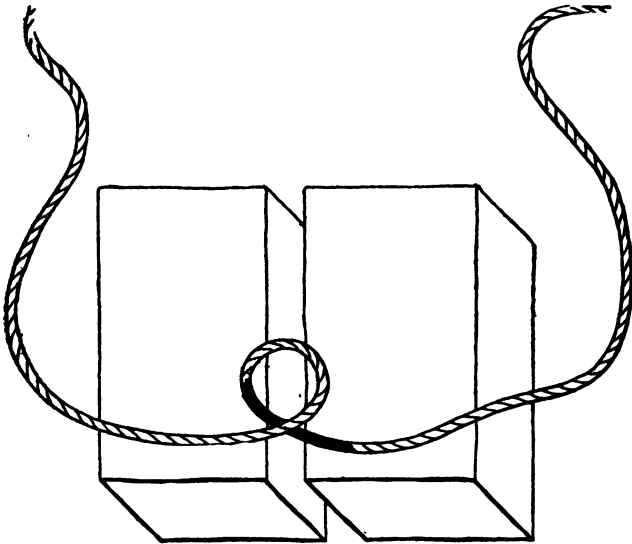

Fig. 1.

*The load being slung to throw the Stirrup Hitch:*

**Fig. 1.** No. 1 throws the lash rope across the pack in such a manner that the center of the rope rests on the center of the pack.

He then forms at this center a bight.

The position of the lash rope is now as shown in Fig. 1.

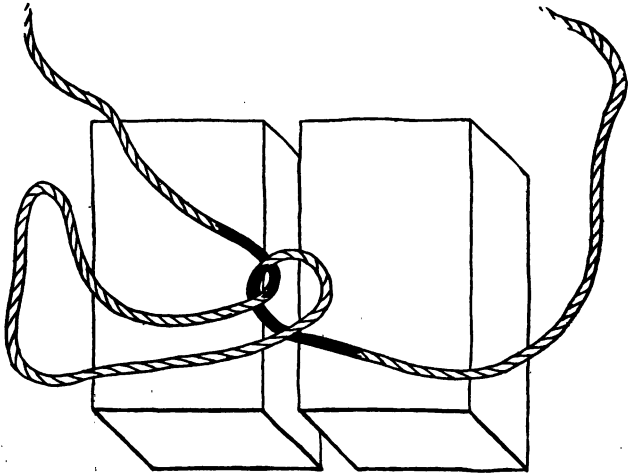

Fig. 2.

**Fig. 2.** *No. 1* now passes the end of the rope on the near side through the bight on the center of the load and in such a manner that a long bight is formed in the rope and that falls nearly to the ground on the near side.  
The position of the lash rope is now as shown in **Fig. 2.**



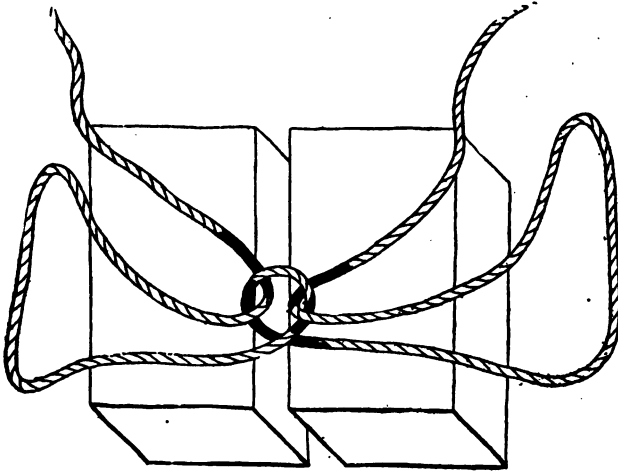

Fig. 3.

*Fig. 3.* No. 2 on the off side takes the end of the rope on the off side and passes it through the bight on the center in such a manner that a long bight is formed and that drops nearly to the ground on the off side

The position of the lash rope is now as shown in *Fig. 3.*

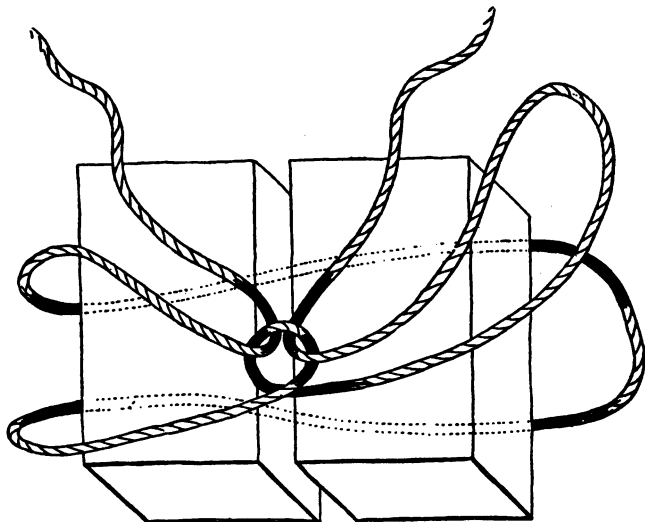

Fig. 4.

*Fig. 4.* No. 1 now passes the long bight on the near side underneath the mule's belly to No. 2. No. 2 grasps it as it is passed to him and draws it well out on the off side. The position of the lash rope is now as shown in *Fig. 4.*

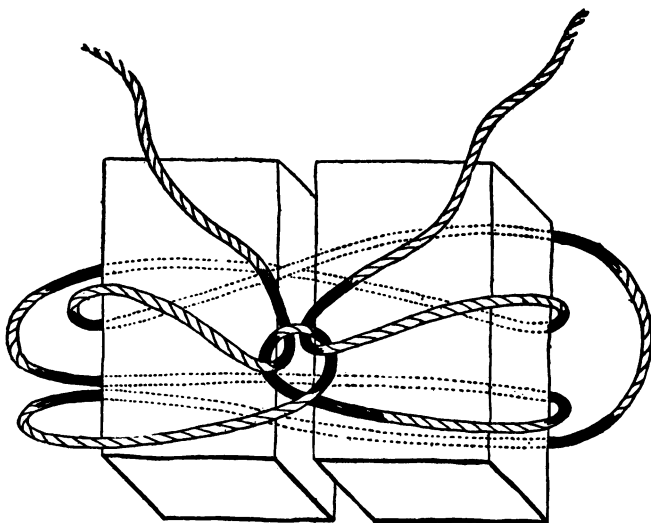

Fig. 5.

*Fig. 5.* No. 2 now takes the long bight on the off side and passes it down and through the bight he has just received from No. 1 at the same time continuing and passing it on underneath the mule's belly to No. 1.

No. 1 grasps this off bight as it is passed to him and draws it well out on the near side.

The position of the lash rope is now as shown in Fig. 5.

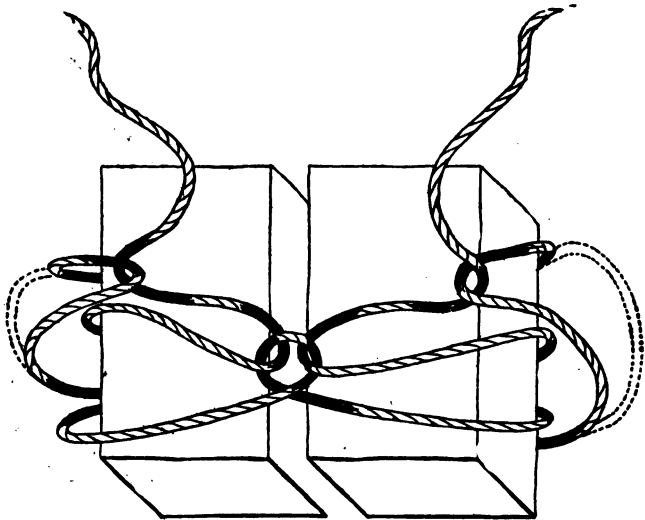

Fig. 6.

**Fig. 6.** *No. 1* brings the bight he has just received well up and slightly overlapping on the near side of the pack.

He then passes the end of the rope on the near side up and through this bight.

*No. 2* at the same time on the off side brings the bight he has just received well up and slightly overlapping on the off pack

He then passes the end of the rope on the off side up and through this bight.

The hitch is now ready to cinch.

The position of the lash rope is now as shown in **Fig. 6.**

When ready to cinch *No. 1* commands:

"Cinch."

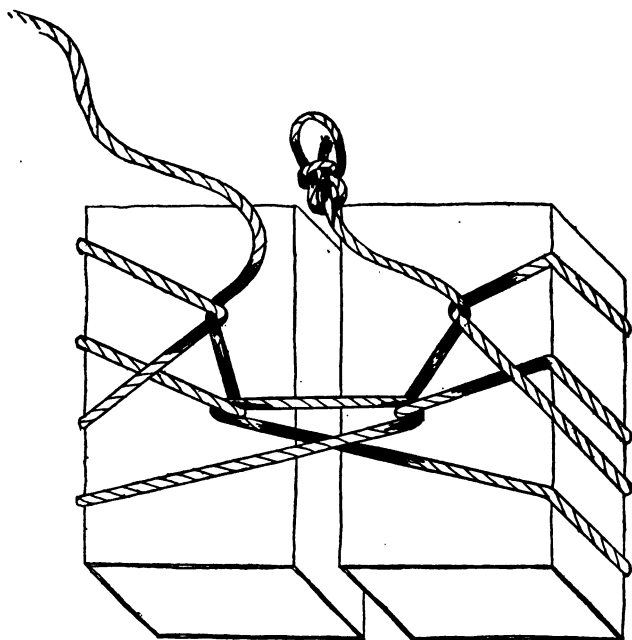

**Fig. 7.** The hitch is now cinched.

In this case it is necessary that both *No. 1* and *No. 2* begin and heave at the same time on the first turns and take the slack at the same time. This is because there is no hook nor friction of rope to hold against the cinching process at first. Virtually it is that one packer holds while the other heaves on the first turns. It is practically a simultaneous operation and for simplicity is so given.

*No. 2* forms a bowline at the end of the lash rope on the off side.

The position of the lash rope is now as shown in *Fig. 7*.

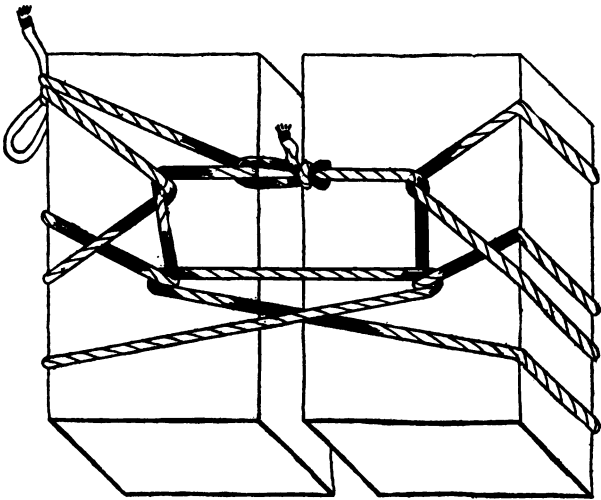

Fig. 8.

**Fig. 8.** *No. 2* now passes the bowline he has formed over and across the forward part of the load to *No. 1*.

*No. 1* passes the end of the rope on the near side through the bight of the bowline and heaves on the rope.

This completes the final cinch and he then makes fast the end of the rope.

The position of the lash rope is now as shown in **Fig. 8**.

**SADDLE HITCH**

As its name implies, this is a hitch to be used on any riding saddle. In a saddle that has no rings any loop that can be formed by a strap will do; also the stirrups may be crossed, lashed in place and the saddle hitch used as described. Also, if there is no means of lashing the crossed stirrups in place, the saddle hitch may be used by passing the rope that is between the two bights *under* the belly of the animal, and making the hitch as described but *under* the animal instead of across the saddle.

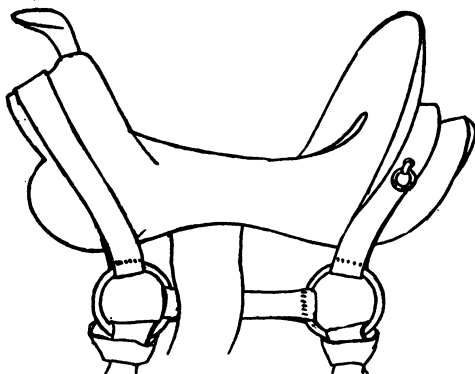

Fig. 1.

**Fig. 1.** The ordinary stock saddle, with a double cinch, has been selected to illustrate this hitch. But it

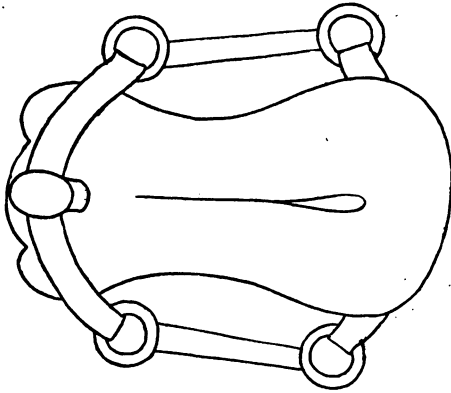

Fig. 1. a

may be adapted easily to any saddle by following the following principles. The second diagram shows the plan of the saddle.



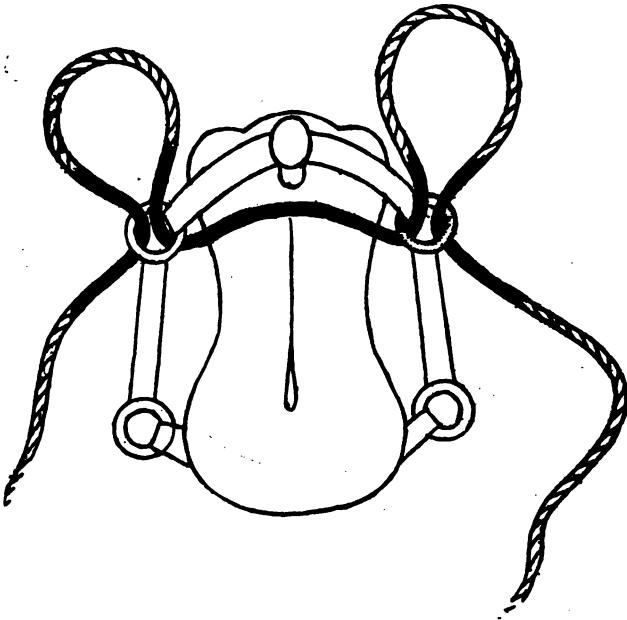

Fig. 2

*Fig. 2.* The *Packer* throws the lash rope across the saddle so that an equal portion falls on each side. Through the ring on the near side he doubles a portion of the rope making a bight that comes out beyond. He now does the same on the off side with the ring there. The position of the lash rope is now as shown in *Fig. 2.*

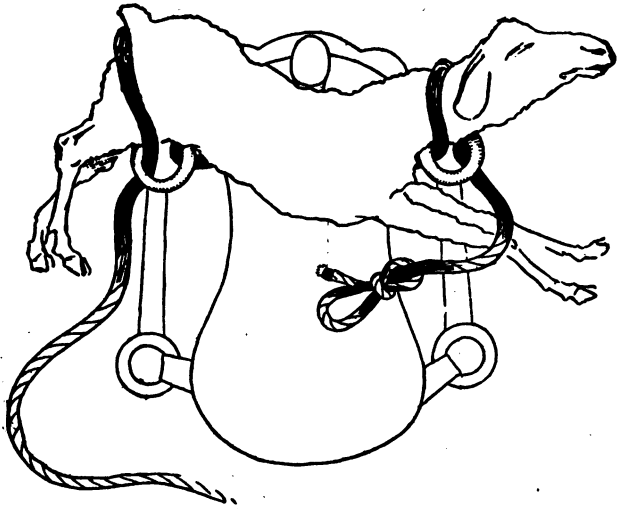

Fig. 3

**Fig. 3.** The packer then places the load (this is a hitch that will rarely be used except for game or emergency supplies) across the saddle. The hind legs or haunches are thrust through the bight on the near side. The head, neck or fore-quarters, through the bight on the off side. The packer makes a bowline on the end of the rope on the off side. The load and lash rope are now as shown in *Fig. 3*.

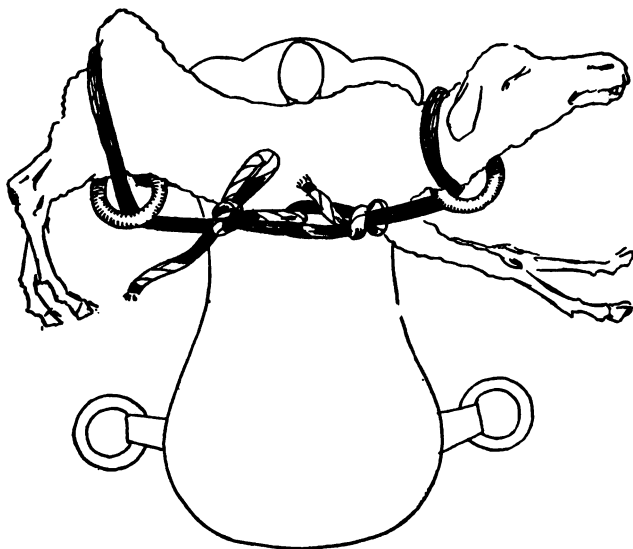

Fig. 4

**Fig. 4.** The packer now takes the end of the rope on the near side and passes it through the bight of the bowline from the off side, cinching the lash rope as tight as the circumstances may require. The position of the load and lash rope is now as shown in Fig. 4.

### TO CONSTRUCT A TRAVOIS

Made with two poles, light as can be had in the country, from *14* to *16 feet* long. The diameter at the tips should not be greater than *2 inches*.

At the butt, *6 inches* from the end, cut a notch deep enough to hold the turns of a rope.

Lay a manta or pack cover (or blanket if nothing else is available) on the ground. Place the poles at the two opposite sides leaving about *6 feet* of the butts beyond the ends to act as shafts for the mule.

Roll the poles toward each other thereby winding up the pack cover until it takes on the proportions of a litter or stretcher, i. e., with a space left between the poles of *2* or *3 feet*. Fasten the rolled pack cover or blanket by lashings or nails, horseshoe nails will be always available in any pack outfit.

Lash two cross sticks to hold the poles at their distance.

At the butts of the poles make fast a rope at the notch previously cut and passing from one pole to the other as a sling. This sling should have a slack of about *18 inches*.

At the tips fasten another sling with plenty of slack, or two ropes. These are to use in lifting the end of the travois in passing over bad ground or through fords.

The travois is now as shown in *Fig. 1*.

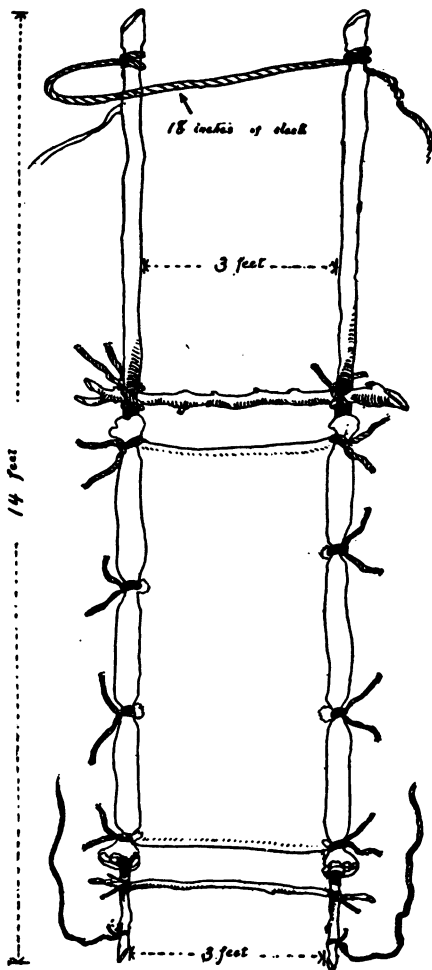
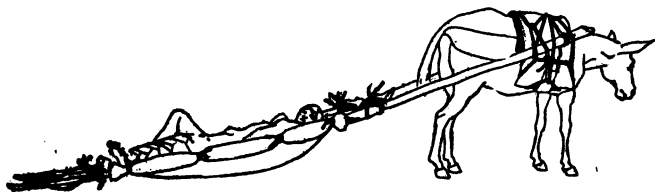
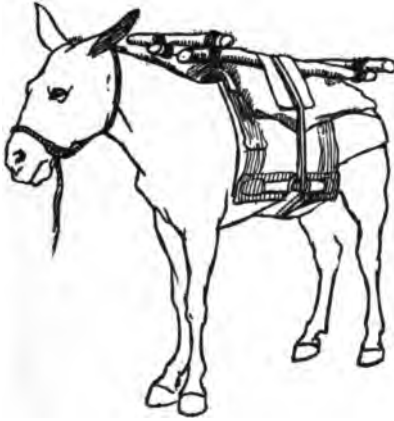

Fig. 1



Place the sling at the butts over the pack saddle or aparejo and lash with the *pole hitch*. (See Pole Hitch, page 114.)

The travois is now as shown in *Fig. 2*.



**Suggestion for constructing litter for pack transportation.**



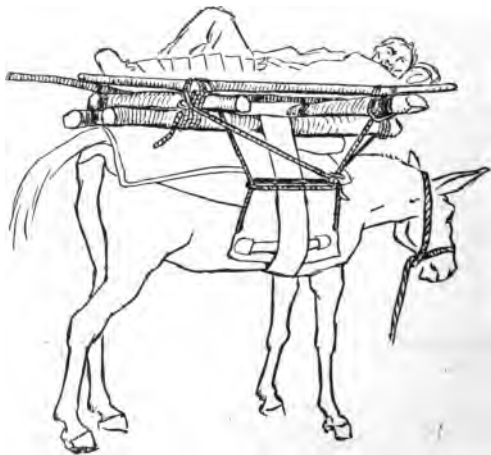

The animal must be well blanketed and the foundation poles for the litter well lashed on. The litter is then securely fastened to the foundation poles as shown. (See Hitches.)



## APPENDIX

## SPICES

There are two forms of splices used for joining two ropes together, a "short splice" and a "long splice."

The short splice is used where a rope does not have to run through a block.

The long splice is used where the diameter of a rope must not be increased and so that it may still pass through a block. The long splice takes a good deal of rope.

A splice weakens a rope about one-eighth.

A cut splice is also shown but it is not recommended as it brings the strain on the inside of the splice, the weakest part.

*Short Splice*—Where a rope does not need to run through a block, this is a quick splice. It is more troublesome than the eye splice though the principle is identical.



Fig. 1.

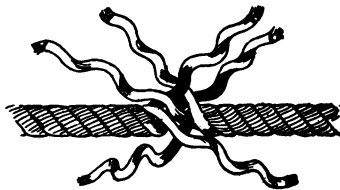

Fig. 2.

The two ends, unlaied, should be brought together carefully with the strands opposite and between as in *Fig. 1* and *Fig. 2*. It is best to seize, i. e., wrap them temporarily, in this position.



Fig. 3.

The free strands are then interwoven with the laid up rope, over and under (*Fig. 3*) and the result will be as *Fig. 4*.



Fig. 4.

If a sufficient splice is made this may be tapered by cutting off fibers, but this is not necessary as it is a patch job in itself.

Splicing cannot be successfully described, the exactness becomes confusing in its length. But the process is simple with a rope in one's hands and the diagram before the eyes.

*Long Splice.*—This splice is used when the rope is to run through a block or when the diameter of the rope must not be enlarged.

Unlay the strands of each rope for a convenient length and bring together as for a short splice.

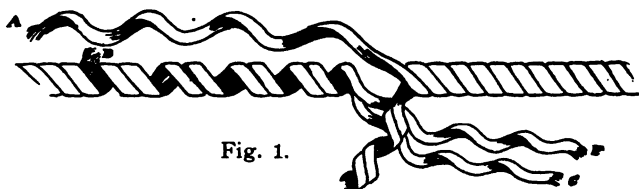

Fig. 1.

*Fig. 1 and 2.* Unlay to any desired length Strand D of one rope, laying in its place the nearest strand A of the other rope.

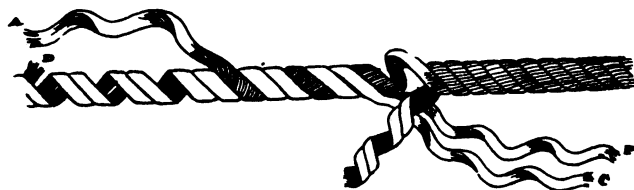

Fig. 2.

*Fig. 3 and 4.* Repeat the operation in the opposite direction with the other two strands, C and F.

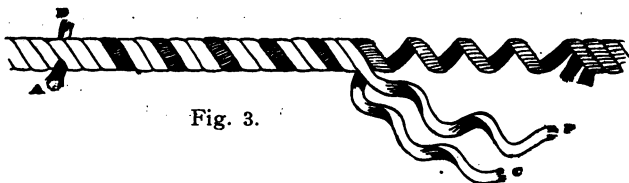

Fig. 3.



Fig. 4.

The ends of the strands should not be trimmed off close until the rope has been thoroughly stretched by work.

The ends may be fastened by tying, running between strands, whipping with a few turns, or sewing.

**Eye Splice**—In order to form a neat eye in the end of a rope either empty or around a thimble—a thimble being a metal ring or loop to prevent chafing the outside being dished to fit the round of the rope—the strands are unlaidd for a distance equal to three times the circumference of the rope and laid down



Fig. 1.

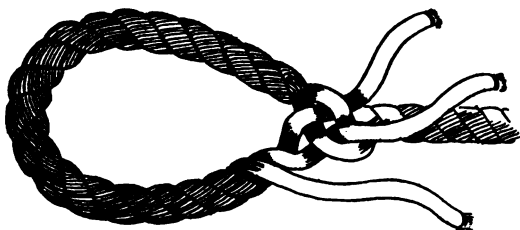

Fig. 2.

*Eye Splice*

on the rope after having shaped or fitted the eye to the required size. The strands of the rope are now pried open and the unlaid strands passed through as shown in the diagrams.

This weaving should be continued over and under as shown until the length of strands (three times the circumference of the rope) are used up.



Fig. 3.

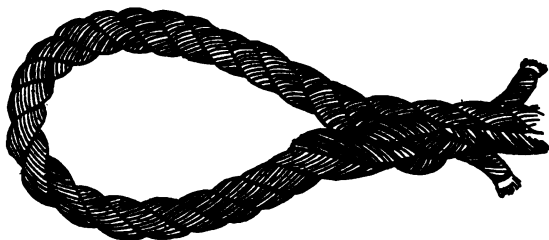

Fig. 4.

*Eye Splice*

To taper the splice the unlaidd strands should have a portion of the fibers cut out after the first or second weave has been made. The whole may then be whipped if desired. A marlinspike or tapered round stick should be used to pry open the strands.

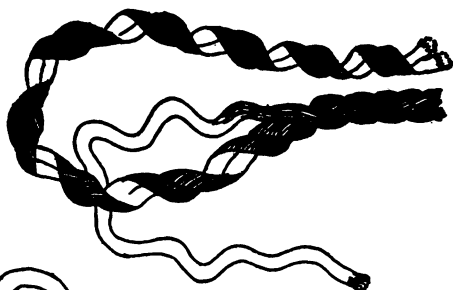

Fig. 1.

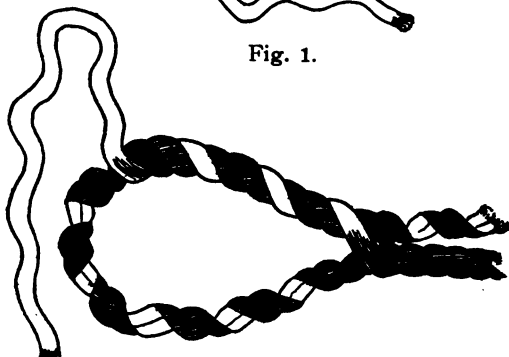
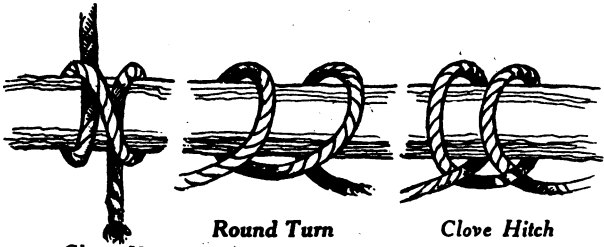
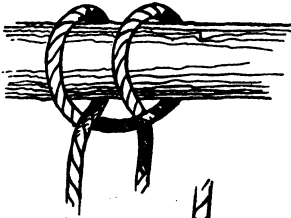

Fig. 2.

**Flemish Eye**—Is made by unlaying one strand of rope a little more than the circumference of the eye required.

The two stranded part is now bent around in the eye and laid alongside the rope.

The strand which was removed is laid in its own groove *but in a backward direction* and three strands having been tapered by cutting away from time to time some of the fibers *after the eye is complete* the tapered strands can be tucked in to make a neat finish, as in a splice. It may also be whipped if desired.

*Clove Hitch**Round Turn**Clove Hitch*

A Clove Hitch will bind against any strain and can easily be cast loose. Round Turn is to take in slack and hold it quickly or to pay out slowly; it is not intended to hold and bind.

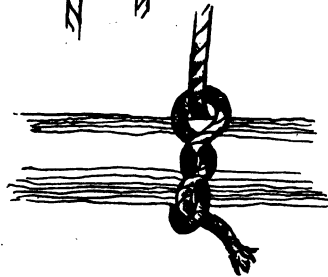

*Timber Hitch*—  
Will hold.  
A quick hitch  
to secure a  
spar or log.

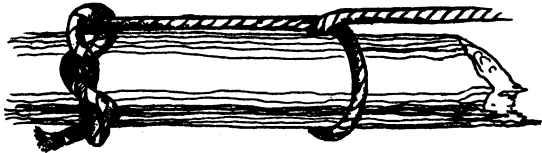
*Timber Hitch*

*Timber Hitch and Half Hitch*—an improvement on the former.





***Single Sheet Bend***—or Weaver's Knot, for joining ends of ropes together and without jamming, also to join one rope onto an eye splice



***Double Bend***—Much more secure than the single bend.



*Mousing*



*Lark's Head*

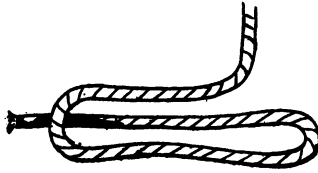

*Cat's Paw* Fig. 1.

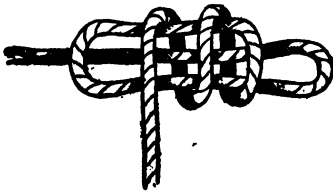

*Cat's Paw* Fig. 2.



*Cat's Paw* Fig. 3.

**Bowline—**

For making a loop or bight in a rope that will not slip.  
(Upper diagram).

**Running Bowline—**

Used where a running noose is desired and where the smaller loop cannot jam or bind.  
(Lower diagram)



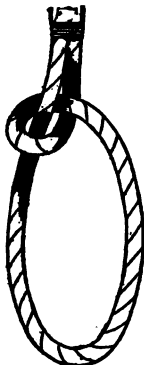

*Half Hitch and Seizing*—A simple, semi-permanent loop.

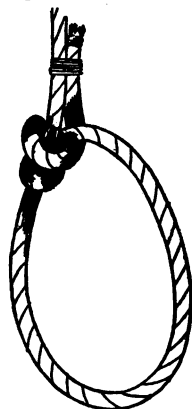

*Midshipman's Hitch*—A much better way of making the above, for the rope jams itself, and there is but little strain on the seizing. A man overboard catching a rope can make this—passing the bight between his legs and pressing the ropes together in his grasp in place of seizing. He could not tie a bowline or a noose unless he had slack.

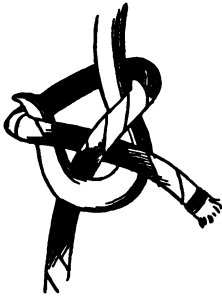

*Modern Midshipman  
Hitch*



*Blackwell Hitch*



*Double Blackwell  
Hitch*



*Nipping a Bight*



Used when strain is to come all or chiefly on one rope.



***Cat's Paw***  
***Another Form***



**Sheepshank—**  
**For shortening**  
**rope without cutting.**

N. B.—In the following diagrams the knots, hitches, bends, etc., are shown open. They should be tightened and jammed to hold.

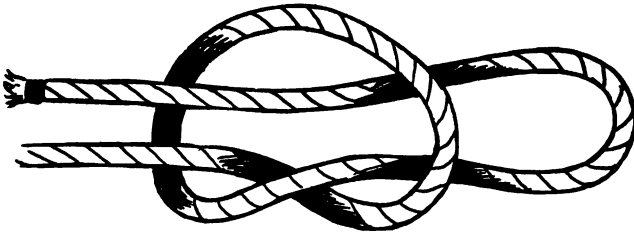

*Running Knot*—or slip knot.

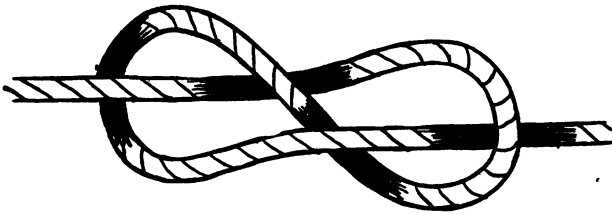

*Figure Eight Knot*—Used for the same purpose as thumb knot.

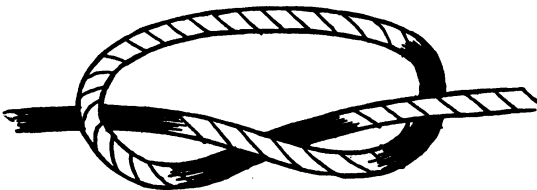

*Thumb or Overhand Knot*—Used in end of rope to keep it from fraying or running through sheave of a block.

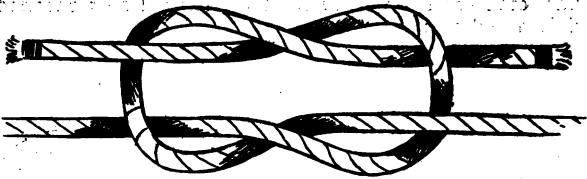

*Granny Knot*—Worthless, will slip; notice the bights, in and out.

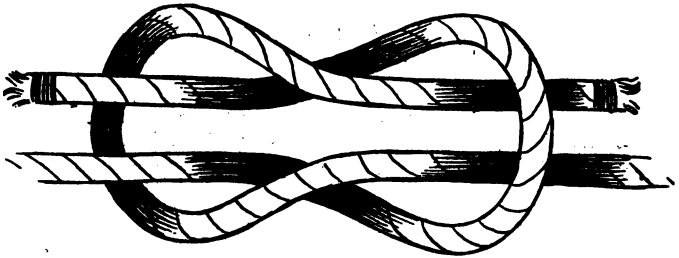

*Square Knot or Reef Knot*—Will hold.

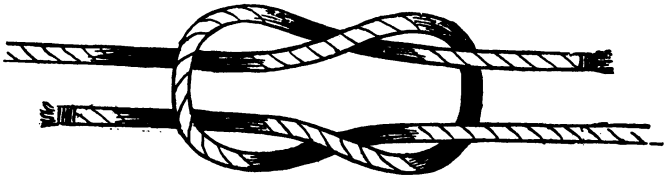

*Thief Knot*—Worthless, will slip; notice ends on opposite sides.



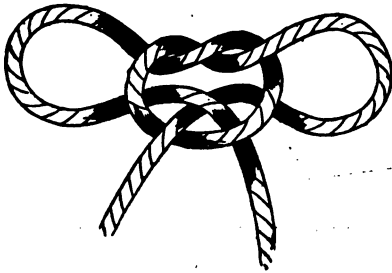

***True Lover's Knot or Double Bow***—Effective in securing wrists of prisoners—as handcuffs, drawing tight and securing with a reef knot. With small twine a man's thumbs may be thus tied behind his back effectively holding him helpless.



***Slip Knot or Draw Knot***—Doubling back a reef knot, another form of slip knot.

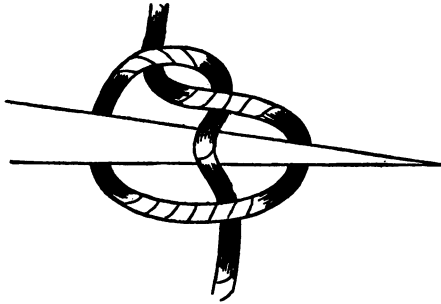

***Marlinspike Hitch.***—Used for putting on stoppings, seizing, etc. The turns are made on a marlinspike or a hard wood stick as shown. The wrapping is started and the stick, at right angles to the rope to be wound, is passed in a continuous circling around and around. It keeps a strong tension on the wrapping and feeds the small stuff as it goes, slowly and taut.



**Wall Knot**—This is the first and simplest of the many decorative knots; it is also used on the end of a rope to prevent its slipping through a hole as when made into a rope bucket handle. It is also used as the first step in a shroud knot. Like a splice it can be easier followed in diagrams than in explanation.

Each strand of the end of a rope is brought under and then up through the bight formed by its neighboring strand *to the left*. It must be tightened slowly with a little pull on each strand and so on until all are tight.

The ends may be then tucked in or whipped.

*Fig. 3 A* is a view from the top showing how the strands must be brought up from below and through the bight to the left.

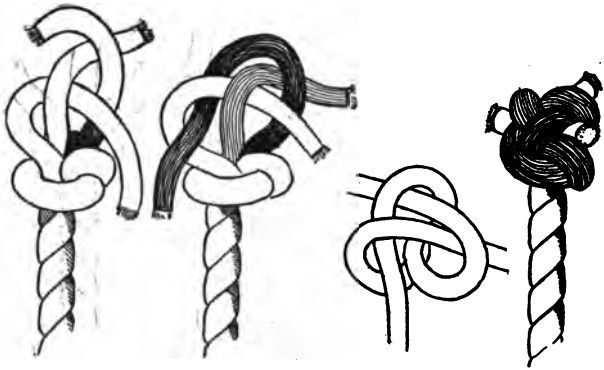

**Crown on Wall**—This may be added to the Wall Knot. The Crown Knot is also the start of a Back Splice sometimes used in place of whipping the end of a rope.

This Crown is the reverse of the Wall Knot as it is made by bringing each strand *over* and then *down* through the bight formed by the neighboring strand.

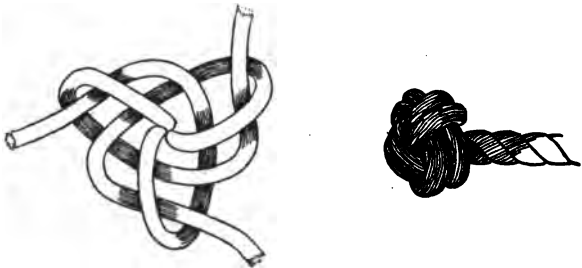

**Double Wall Knot**—Started the same as a Wall Knot and then instead of tightening the ends are again passed *under and up* through the bight just ahead of them.

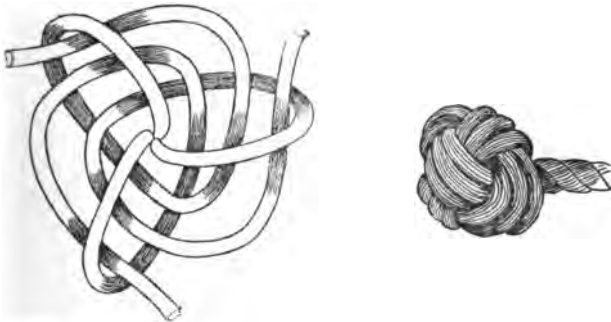

**Treble Wall Knot**—Same as the preceding but continuing the ends under and up through the next bight a third time. The skill in these knots is to tighten them evenly, otherwise they present an irregular appearance.

With any of the Wall Knots the strands may be laid up again into rope so that the knot will be at some distance from the end; this gives a fancy appearance and a number of combinations may be worked out of these various knots.

**Pointing a Rope**—This is an ornamental finish to the end of a rope; it is also useful for a rope that has to be hurriedly rove through a block.

A temporary seizing is put around a rope as far from the end as the beginning of the point. The strands of the rope are unravelled into yarns—the yarns being the small bundles of fibers or strings of which the strand is composed.

All of the yarns at the outside of the rope, that is, those that lie on the circumference, are stopped back (*Fig. 1.*) while those left and forming what is now the core, are cut and scraped down to a tapering shape somewhat like a blunt carrot.

This blunt carrot part is now tightly wrapped with marlin or small stuff so that it becomes a rigid conical end. These operations are shown in an unfinished state in *Fig. 1.*

The rim of yarns around the rope's circumference, and which have been stopped back, are now known as nettles and are separated into two divisions.

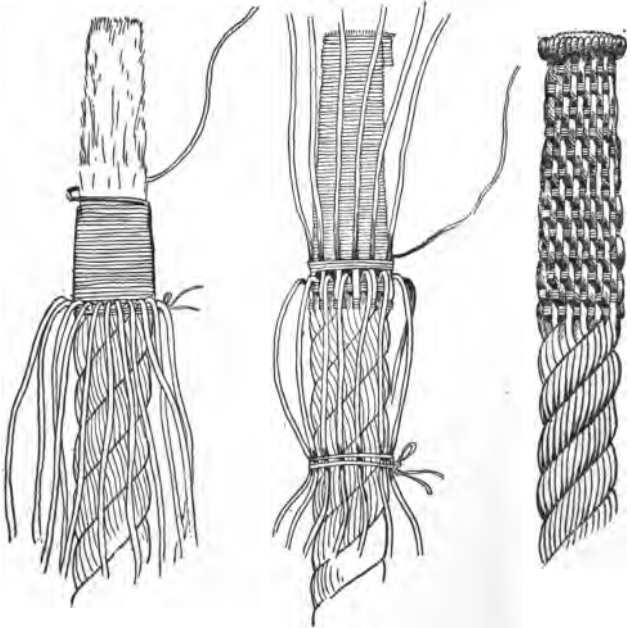

Fig. 1

Fig. 2

Fig. 3

Each alternating nettle—or odd numbered one—is stopped back.

The even numbered ones are brought forward and three turns of twine are taken round them, the last turn being given a half hitch to hold it in place.

The even numbered nettles are now lightly stopped back and the odd nettles brought forward and three turns of twine taken around them in the same manner as before. This twine is the *warp*. (See Fig. 2.) This *weaving* is continued until the end. To keep the taper it will be necessary to cut out or thin down the yarns from time to time. If cut out, their ends can be held down by the wrapping of the warp.

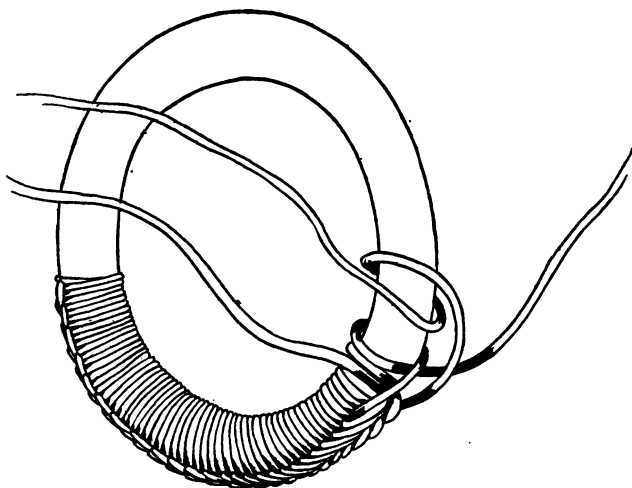

To finish, the nettles are given a round turn over the last three wrappings of the warp. The warp is hauled taut, the nettles are pulled taut and the ends cut off close. The whole may be shellacked.

*Plaited Ring*—An ornament for rings where they are not used for passing latigoes or lashings. Two lengths of small stuff are taken, one twice the length of the other.

At the middle part of the long piece, make a Clove Hitch around the ring that at the same time, takes in and securely fastens one end of the shorter piece. This gives three free ends. Each free end is made into a half hitch.

The ornamenting may stop when that part of a ring is reached where the chafe comes. The ends are fastened by tucking them under the preceding turns. A coat of shellac may be given the whole.

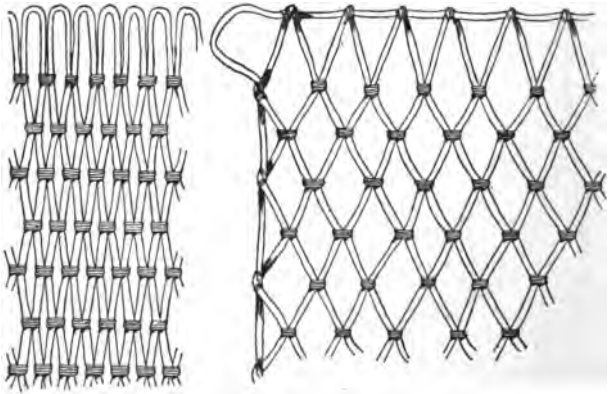

***Sling Net for Cargo***—Sometimes useful in grouping small articles in a load where pack manta is not available.





Fig. 1

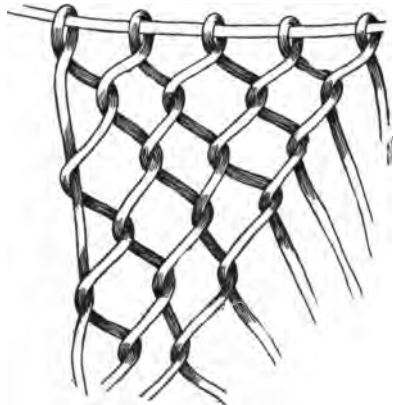

Fig. 1

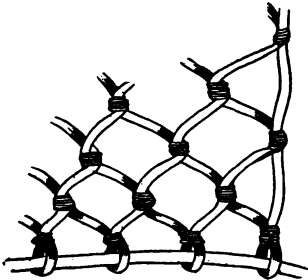

Fig. 2

*Paunch Mat*



Fig. 2

*Sling Net*

## INDEX

	PAGE
<b>Aparejo—</b>	
<i>Adjusting</i> .....	30
<i>Aparejo Cover, see Sobre-jalma</i>	
<i>Care of</i> .....	31
<i>Cincha for, Specifications</i> .....	42
<i>Definition</i> .....	11
<i>Description</i> .....	24
<i>Padding for</i> .....	27
<i>Ribs for</i> .....	24
<i>Specifications for</i> .....	11
<i>Bell Horse</i> .....	11
<i>Bend, Single Sheet</i> .....	181
<i>Bend, Double Sheet</i> .....	181
<i>Bivouac</i> .....	11
<i>Blackwall Hitch</i> .....	182
<b>Blind—</b>	
<i>Definition</i> .....	11
<i>Specifications for</i> .....	45
<i>Bowline</i> .....	183
<i>Brake</i> .....	11
<i>Breast Strap</i> .....	11
<i>Bunch</i> .....	11
<i>Causes of</i> .....	32
<i>Treatment for</i> .....	32
<i>Belly</i> .....	33
<b>Cargo—</b>	
<i>Definition</i> .....	11
<i>To Make Up</i> .....	52
<i>To Sling</i> .....	60
<i>Weights of</i> .....	16
(See Slings)	

	PAGE
<i>Cargador</i> .....	11, 15
<i>Cat's Paw</i> .....	182, 186
<i>Chief Packer</i> .....	11
<i>Cincha</i> —	
<i>Definition</i> .....	11
<i>Specifications for</i> .....	44
<i>Cordage, see Appendix</i> .....	173
<i>Corona</i>	
<i>Definition</i> .....	11
<i>Specifications for</i> .....	44
<i>Cross Sling</i> .....	75
<i>Dock-piece</i> .....	12
<i>Sore</i> .....	30
<i>Specifications for</i> .....	39-41
<i>Crupper</i> —	
<i>Definition</i> .....	11
<i>Lacing—to Aparejo</i> .....	29
<i>Specifications for</i> .....	39
<i>Definition</i> .....	11
<i>Dock</i> —	
<i>Diamond Hitch, Single</i> .....	78
<i>Diamond Hitch, Double</i> .....	92
<i>Cross Tree</i> —	
<i>Definition</i> .....	11
<i>Description</i> .....	122, 124
<i>Hitch</i> .....	132
<i>Double Bend</i> .....	181
<i>Double Sling</i> .....	74
<i>Endurance, Records of</i> .....	16,17
<i>Flemish Eye</i> .....	179
<i>General Rules</i> .....	14
<i>Girth</i> .....	12
<i>Hitch</i> .....	12
<i>Hitches, Packing</i> —	
<i>Cross-Tree Hitch</i> .....	132
<i>Diamond Hitch, Single</i> .....	78
<i>Diamond Hitch, Double</i> .....	92
<i>Pole Hitch</i> .....	115
<i>Lifting Hitch</i> .....	146
<i>Saddle Hitch</i> .....	163
<i>Squaw Hitch</i> .....	140
<i>Stirrup Hitch</i> .....	155
<i>Travois, see Pole Hitch</i> .....	170



	PAGE
<i>Pack Blanket</i> .....	12
" (To lair up) .....	52
" Cover, Specifications .....	46
" Mule, Standard of .....	19
" " Description of .....	12
" " Diseases of .....	23
" Train .....	12, 15
" (see also <i>Marches and Endurance</i> )	
" Master .....	12, 15
<i>Packer</i> .....	12, 15
<i>Padding</i> .....	47
<i>Picket Rope</i> .....	12
<i>Pole Hitch</i> .....	114
<i>Records of Endurance</i> .....	16
<i>Rendering Ring</i> .....	13
<i>Ribs, for Aparejo</i> .....	24, 47
<i>Riding Load</i> .....	13
<i>Sling for, Cross Sling</i> .....	75
<i>Hitch for</i> .....	92
<i>Rigging</i> .....	13
<i>Ring, Plaited</i> .....	195
<i>Rope—</i>	
<i>Lair</i> .....	12, 46
<i>Lash</i> .....	12, 46, 48
<i>Splices, etc</i> .....	173
<i>Rules, General</i> .....	14
<i>Running Bowline</i> .....	183
" <i>Part</i> .....	13
" <i>Rope</i> .....	13
<i>Saddle Hitch</i> .....	163
<i>Saw Buck Sling, No. 1</i> .....	125
<i>Saw Buck Sling, No. 2</i> .....	128
<i>Sheepshank</i> .....	186
<i>Single Sheet Bend</i> .....	181
<i>Sling, Double</i> .....	74
<i>Sling, Cross</i> .....	57
<i>Slinging Cargo</i> .....	60
" " <i>One-Man Sling</i> .....	66
<i>Sling Rope</i> .....	13, 46
<i>Sobre-jalma</i>	
<i>Definition</i> .....	13
<i>Specifications</i> .....	41
<i>To fasten</i> .....	30

	<b>PAGE</b>
<i>Splices</i> .....	173
<i>Eye</i> .....	176
<i>Long</i> .....	175
<i>Short</i> .....	173
<i>Squaw Hitch</i> .....	140
"    " <i>Pack Mule</i> .....	19
<i>Standard of Organization</i> .....	15
<i>Standing Rope</i> .....	13
" <i>Part</i> .....	13
<i>Stirrup Hitch</i> .....	155
<i>Striding Load</i> .....	13
<i>Top Load</i> .....	13
<i>Travois</i> .....	168, 173
<i>Travel, Rate of</i> .....	16
<i>Weights of Cargoes</i> .....	16
<i>Wiman One-Man Hitch</i> .....	17











This book should be returned to  
the Library on or before the last date  
stamped below.

A fine of five cents a day is incurred  
by retaining it beyond the specified  
time.

Please return promptly.

